

District of Summerland Zoning Bylaw



Schedule “A” to Bylaw Number 2000-450

Adopted: September 12, 2011

Last Update: August 1, 2018.

This is a consolidated copy to be used for convenience only. Users are asked to refer to the Zoning Bylaw as amended from time to time to verify accuracy and completeness.



Table of Contents

1.0	GENERAL ADMINISTRATION.....	1-1
1.1	TITLE 1-1	
1.2	PURPOSE.....	1-1
1.3	APPLICATION.....	1-1
1.4	ENFORCEMENT.....	1-1
1.5	PROHIBITIONS AND PENALTIES.....	1-2
1.6	SEVERABILITY.....	1-2
1.7	HEADINGS.....	1-2
2.0	DEFINITIONS.....	2-1
2.1	DEFINITIONS AND TERMINOLOGY.....	2-1
3.0	ESTABLISHMENT OF ZONES.....	3-1
3.1	ESTABLISHMENT OF ZONES.....	3-1
3.2	ZONE BOUNDARIES.....	3-2
3.3	UNDERSIZED LOTS.....	3-3
3.4	USES AND REGULATIONS.....	3-3
4.0	GENERAL REGULATIONS.....	4-1
4.1	USES PERMITTED IN ALL ZONES.....	4-1
4.2	PROJECTIONS INTO SETBACKS.....	4-1
4.3	HEIGHT OF BUILDINGS AND STRUCTURES.....	4-2
4.4	HERITAGE DESIGNATED BUILDINGS.....	4-3
4.5	ACCESSORY BUILDINGS AND STRUCTURES.....	4-3
4.6	VEHICLE STORAGE.....	4-3
4.7	SETBACKS FROM HIGHWAYS AND MAJOR STREETS.....	4-4
4.8	SWIMMING POOLS AND ARTIFICIAL BODIES OF WATER.....	4-4
4.9	BUILDING ENVELOPE.....	4-4
5.0	LANDSCAPING REGULATIONS.....	5-1
5.1	LANDSCAPE REQUIREMENTS.....	5-1
5.2	LANDSCAPING AND SCREENING.....	5-1
5.3	LANDSCAPE RESTRICTIONS.....	5-1
5.4	LANDSCAPE STANDARDS.....	5-1
5.5	FENCES & RETAINING WALLS.....	5-2
6.0	PARKING & LOADING REGULATIONS.....	6-1
6.1	VEHICLE PARKING AND LOADING PROVISIONS.....	6-1
6.2	DESIGNATED PARKING SPACES.....	6-5
6.3	SHARED AND OFF-SITE PARKING.....	6-6
6.4	FEE IN LIEU OF PARKING.....	6-7
6.5	VEHICLE PARKING SPACE DESIGN STANDARDS.....	6-7
6.6	VEHICLE PARKING SPACE LOCATION AND ACCESS STANDARDS.....	6-8
6.7	LOADING SPACE STANDARDS.....	6-9
6.8	LOADING SPACE LOCATION STANDARDS.....	6-9
6.9	LIGHTING.....	6-9
6.10	BICYCLE PARKING SPACE STANDARDS.....	6-10
7.0	SPECIFIC USE REGULATIONS.....	7-1
7.1	APPLICATION.....	7-1
7.2	BED & BREAKFAST HOMES.....	7-1
7.3	SECONDARY SUITES.....	7-1
7.4	CARRIAGE HOUSES.....	7-2

7.5	DOCK & BOAT LIFT REGULATIONS	7-2
7.6	HOME OCCUPATIONS	7-3
7.7	CHILD CARE CENTRES, MINOR AND MAJOR	7-6
7.8	GROUP HOMES, MINOR	7-6
7.9	SERVICE STATIONS AND GAS BARS.....	7-7
7.10	TEMPORARY USE PERMIT AREAS.....	7-7
7.11	RENEWABLE ENERGY SYSTEMS AND INFRASTRUCTURE	7-9
8.0	AGRICULTURAL ZONES	8-1
8.1	A1 AGRICULTURAL SMALL ACREAGE ZONE A1	8-1
8.2	A2 AGRICULTURAL LARGE ACREAGE ZONE A2	8-7
9.0	RURAL RESIDENTIAL ZONES	9-1
9.1	CR1 COUNTRY RESIDENTIAL ZONE CR1	9-1
10.0	URBAN RESIDENTIAL ZONES	10-1
10.1	RSD1 RESIDENTIAL MEDIUM LOT ZONE RSD1	10-1
10.2	RSD1(i) RESIDENTIAL SINGLE DETACHED INTENSIVE ZONE RSD1(i)	10-3
10.3	RSD2 RESIDENTIAL LARGE LOT ZONE RSD2.....	10-5
10.4	RSD3 RESIDENTIAL ESTATE LOT ZONE RSD3	10-7
10.5	RDH RESIDENTIAL DUPLEX HOUSING ZONE RDH	10-10
10.6	RPN – RESIDENTIAL POCKET NEIGHBOURHOOD ZONE RPN.....	10-13
10.7	RSH RESIDENTIAL STRATA HOUSING ZONE RSH.....	10-16
10.8	RMD RESIDENTIAL MEDIUM DENSITY ZONE RMD.....	10-19
10.9	RHD RESIDENTIAL HIGH DENSITY ZONE RHD	10-21
10.10	RMH RESIDENTIAL MANUFACTURED HOUSING ZONE RMH.....	10-24
11.0	COMMERCIAL ZONES.....	11-1
11.1	CN NEIGHBOURHOOD COMMERCIAL ZONE CN	11-1
11.2	CT1 TOURIST COMMERCIAL ZONE CT1.....	11-3
11.3	CH HIGHWAY COMMERCIAL ZONE CH.....	11-5
11.4	CT2 CAMPGROUND ZONE CT2	11-7
11.5	CB1 CENTRAL BUSINESS ZONE CB1.....	11-9
11.6	CB2 SHOPPING CENTRE ZONE CB2	11-12
11.7	CM HEAVY COMMERCIAL ZONE CM.....	11-15
12.0	INDUSTRIAL ZONES.....	12-1
12.1	M1 LIGHT INDUSTRIAL ZONE M1	12-1
12.2	M2 HEAVY INDUSTRIAL ZONE M2.....	12-4
12.3	M3 AGRI-INDUSTRIAL ZONE M3.....	12-7
12.4	M4 RESOURCE INDUSTRIAL ZONE M4	12-9
12.5	M1-A BUSINESS INDUSTRIAL ZONE	12-11
13.0	PUBLIC, OPENLAND & INSTITUTIONAL ZONES	13-1
13.1	PR1 PARKS AND RECREATION ZONE PR1	13-1
13.2	FG FORESTRY GRAZING ZONE FG	13-3
13.3	PP PRESERVATION & PROTECTION ZONE PP.....	13-5
13.4	I INSTITUTIONAL ZONE I.....	13-6
14.0	COMPREHENSIVE DEVELOPMENT ZONES	14-1
14.1	CD COMPREHENSIVE DEVELOPMENT ZONES	14-1
14.2	CD1 - COMPREHENSIVE DEVELOPMENT ZONE.....	14-3
14.3	CD2 – COMPREHENSIVE DEVELOPMENT ZONE	14-5
14.4	CD3 – COMPREHENSIVE DEVELOPMENT ZONE	14-7
14.5	CD4 - COMPREHENSIVE DEVELOPMENT ZONE.....	14-9
14.6	CD5 – COMPREHENSIVE DEVELOPMENT ZONE	14-11

14.7	CD6 – COMPREHENSIVE DEVELOPMENT ZONE	14-12
14.8	CD7 – COMPREHENSIVE DEVELOPMENT ZONE	14-1
14.9	14-1	
14.10	CD9 – COMPREHENSIVE DEVELOPMENT ZONE	14-2
15.0	WATER ZONES.....	15-3
15.1	WZ1 – RECREATIONAL WATER USE ZONE 1.....	15-3
15.2	WZ2 – RECREATIONAL WATER USE ZONE 2.....	15-4
15.3	WZ3 – INTENSIVE WATER USE ZONE	15-5
16.0	SUMMARY OF ZONING BYLAW AMENDMENTS	16-7

1.0 General Administration

1.1 Title

1.1.1 This Bylaw may be cited as the “Summerland Zoning Bylaw 2000-450 ”.

1.2 Purpose

1.2.1 This Bylaw is to provide regulations within the District of Summerland governing:

- (a) the *Use* of land, *Buildings* and *Structures*;
- (b) the *Density* of the *Use* of land, *Buildings* and *Structures*;
- (c) the siting, size and dimensions of *Buildings*, *Structures*, and parking;
- (d) the provision of *Landscaping* and screening;
- (e) the area, shape and dimensions of all parcels of land, *Lots*, or properties that may be created by subdivision; and
- (f) the requirements for parking and loading.

In addition to this Bylaw, a person is responsible for ascertaining and complying with requirements of all other applicable municipal bylaws, and Provincial or Federal statutes and regulations.

1.2.2 This Bylaw applies to all of the area within the District of Summerland except where otherwise specifically stated.

1.3 Application

1.3.1 This Bylaw shall take effect upon the date of adoption.

1.3.2 No land, *Building*, or *Structure* within the District of Summerland shall be developed, used, constructed, erected, modified, converted, enlarged, reconstructed, altered, placed or maintained except in conformity with the provisions of this Bylaw.

1.4 Enforcement

1.4.1 The *District’s Manager of Development Services*, Building Inspector, Bylaw Enforcement Officers, or any other employee authorized by Council are authorized to enter, at reasonable times, upon any property and into any building in order to ascertain whether the Bylaw requirements are being met and the Bylaw regulations are being observed.

1.4.2 No person shall prevent or obstruct or seek to prevent or obstruct an authorized official from carrying out any official duty under this Bylaw.

1.5 Prohibitions and Penalties

- 1.5.1 No person shall contravene, cause, suffer or permit a contravention of this Bylaw.
- 1.5.2 No person shall commence or undertake a *Use* which is not permitted by this Bylaw.
- 1.5.3 Every person who violates any of the provisions of this Bylaw, or who suffers or permits any act or thing to be done in contravention or in violation of any of the provisions of this Bylaw, or who neglects to do or refrains from doing anything required to be done by this Bylaw, shall be guilty upon summary conviction of an offence against this Bylaw and shall be liable to a maximum fine of \$10,000.00.
- 1.5.4 Each day that a violation of this Bylaw is permitted to exist shall constitute a separate offence.
- 1.5.5 Fines for an offence against this Bylaw may also be set out in the District of Summerland Ticketing Information Utilization Bylaw #95-030 and the Bylaw Notice Enforcement Bylaw #2000-375.
- 1.5.6 *Uses* not listed in respect of a particular zone or in [Section 4.1.1](#) of this Bylaw are prohibited.

1.6 Severability

- 1.6.1 If one or more provisions of this Bylaw are, for any reason, declared to be invalid by a court of competent jurisdiction, the invalid provision shall be severed and all remaining provisions shall remain in full force and effect.

1.7 Headings

- 1.7.1 For the purpose of this Bylaw, all headings and other references form part of this Bylaw and shall not be construed as being merely inserted for convenience and reference purposes unless otherwise specified in the Bylaw.

2.0 Definitions

2.1 Definitions and Terminology

2.1.1 All words, or phrases or terms in this Bylaw shall have their normal or common meaning unless specifically defined by the Local Government Act or by the definitions set forth in this section as follows.

A

Bylaw 2013-008 added the following definition- (April 29th, 2013):

Abattoir means a use that provides for the penning and slaughtering of live animals and the preliminary processing of animal carcasses and may include the packing, treating, storing and selling of the product on the premises.

Abut or Abutting means contiguous to, or physically touching, and when used with respect to two Lots, means that the Lots share a common *Property Line*.

Accessory means a *Use*, separate *Building*, or *Structure*, normally incidental, subordinate, exclusively devoted to, permitted only in conjunction with and located on the same *Lot* as the *Principal Use, Building or Structure*

Adjacent, when used with respect to a *Lot*, means contiguous to, or physically touching, if not for a public right-of-way, easement or *Watercourse* other than a lake.

Agricultural Land Commission (ALC) means the governing body assigned to administer regulations and policies relating to the preservation and enhancement of designated *Agricultural Land Reserve (ALR)* land areas for the province, pursuant to the Agricultural Land Commission Act.

Agricultural Land Reserve (ALR) means agricultural land designated as an agricultural land reserve under the Agricultural Land Commission Act.

Agricultural Retail Sales means the retail sale of *Agriculture Products* if the *Agriculture Products* offered for sale are produced on the *Lot* on which the retail sales are taking place or if at least 50 percent of the retail sales area is limited to the sale of *Agriculture Products* produced on the *Lot* on which the retail sales are taking place and the total area, both indoors and outdoors, used for the retail sales of all *Agriculture Products* does not exceed 300m².

Agriculture, General means the *Use* of land for any of the following activities involved in carrying on a farm operation:

- (a) growing, producing, raising or keeping animals or plants including bees, fowl, poultry, livestock and the primary products of those plants or animals;
- (b) cultivation in plantations of any specialty wood crops or specialty fibre crops prescribed by the Minister responsible for Agriculture;
- (c) turf production with approval under the Agricultural Land Commission Act, if required;

- (d) clearing, draining, irrigating or cultivating land;
- (e) using farm machinery, equipment, devices, materials and *Structures*; and
- (f) applying fertilizers, manure, pesticides and biological control agents, including by ground and aerial spraying;

but does not include:

- (a) *Intensive Agriculture Uses*
- (b) raising or keeping game, within the meaning of the Game Farm Act, by a person licensed to do so under that Act;
- (c) raising or keeping fur bearing animals, within the meaning of the Fur Farm Act, by a person licensed to do so under that Act;
- (d) an activity, other than grazing or hay cutting, that constitutes a forest practice as defined in the Forest and Range Practices Act;

Bylaw 2000-459 amended the following definition- Section (e) (November 14, 2011):

- (e) breeding pets, operating a *Commercial Kennel*, or an *Animal Shelter*, Major; and
- (f) growing, producing, raising or keeping exotic animals, except types of exotic animals prescribed by the Minister of Agriculture.

Agriculture, Intensive means the *Use* of land for the propagation of mushrooms, the confined rearing of livestock, poultry and/or fur-bearing animals, or for the operation of a feedlot.

Agriculture, Urban means the act of growing food on a *Lot* zoned for residential or commercial *Use*; in addition to produce grown in a garden, this also includes community gardens, fruit and nut tree production, and the retail sale of produce from the urban agricultural *Use* provided the retail sales area does not exceed 50m², but does not include the keeping of poultry or bees.

Agriculture Products means a commodity that is produced from an *Urban Agriculture Use* or from an agricultural *Use*.

Amenity Space means an unobstructed area or areas available for *Use* by all the *Building's* inhabitants, having no dimension of less than 6.0m and, where outdoors, no slope greater than five percent. *Amenity Space* shall provide for greenery, gardens, recreational space and other leisure activities normally carried on indoors or outdoors and shall exclude areas used for off-*Street* parking, off-*Street* loading, service driveways, private *Balconies*, private *Decks* or private *Patios* and any areas subject to a Section 219 restricted use covenant.

Amusement Establishment means any *Building*, room or area having table games or electronic games played by patrons for commercial entertainment as the *Principal Use*. This does not include carnivals, circuses or *Indoor Recreational Services*.

Animal Shelter means a *Use* which may include outdoor runs, pens or enclosures for the temporary accommodation of animals, but does not include *Commercial Kennels* or *Veterinary Clinics*.

Bylaw 2000-459 added the following definitions (November 14, 2011):

'Animal Shelter, Major' means a Use which may include outdoor runs, pens or enclosures for the temporary accommodation of animals, may include Animal Shelter, Minor, but does not include Commercial Kennels or Veterinary Clinics.

'Animal Shelter, Minor' means a Use which may include indoor animal grooming, training, and daycare, but does not include Animal Shelter, major, Commercial Kennels, or Veterinary Clinics. Animals are not to be kept overnight.

Auctioneering Establishment means a Use which provides for the temporary storage of goods and materials which are to be periodically sold on the *Premises* by public auction.

Autobody Repair Shop means a Use which provides for the repair of damage to motor vehicles and similar vehicles caused by collision, accident, corrosion or age including body repair, frame straightening, painting and upholstery.

Automobile Sales & Rentals means a Use where new or used automobiles or motorcycles are sold, leased or rented and may include the associated storage and servicing of vehicles to be sold, leased and rented as well as the sale of automotive parts.

Automotive & Equipment Repair Shop means a Use which provides for the servicing and mechanical repair of automobiles, motorcycles, snowmobiles and similar vehicles or the sale, installation or servicing of related accessories and parts. Typical Uses include, but are not limited to, transmission shops, muffler shops, and tire shops, but does not include autobody repair shops.

Awning means a roof-like covering of canvas or similar fabric material, which may or may not be retractable, projecting from and being entirely supported from the exterior wall of a *Building*. The projection of *Awnings* into required *Setbacks* is regulated in [Section 4.2](#).

B

Balcony means an unenclosed outdoor seating platform, projecting from the face of a wall, cantilevered or supported by columns or brackets and usually surrounded by a balustrade or railing.

Bar, with respect to a *Dwelling*, means the Use of a room in a *Dwelling* for the dispensing of beverages that may contain a single sink, a fridge, a raised counter and up to 1.8m of cabinetry. A *Bar* may not contain a *Kitchen* or cooking facilities and does not include a dairy bar or a *Gas Bar*.

Basement means that portion of a *Building* located below the *First Storey* of which not more than 1.2m, as measured between the top of the finished floor and the top of the next finished floor above it, is situated above average *Building Grade*.

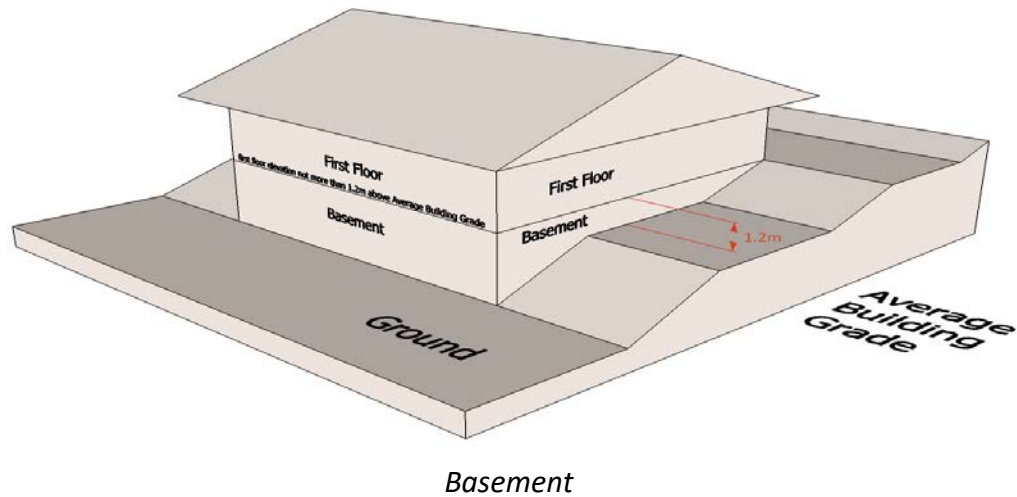

Bed & Breakfast Home means the *Use* of sleeping units, either attached to or part of a resident-occupied *Single Detached Housing* unit for the temporary accommodation of the travelling public for remuneration, and may include serving of meals to those guests. Specific *Use* regulations for *Bed and Breakfast Homes* are in [Section 7.2](#)

Bedroom means a room containing a window, located in a *Dwelling*, which, due to its design or location in the *Dwelling*, is or may be used primarily for sleeping.

Bicycle Parking, Class A means secure, long-term parking for bicycles that is provided in a separate, dedicated room or enclosure. The provision of minimum *Bicycle Parking* requirements must be in conformance with [Section 6.10](#).

Bicycle Parking, Class B means racks or *Structures* with spaces of a minimum width of 0.3m for each bicycle, constructed of sturdy theft-resistant material and shall have secure theft-resistant anchoring to the floor or ground. The provision of minimum *Bicycle Parking* requirements must be in conformance with [Section 6.10](#).

Bylaw 2015-024 amended the following definition – Brewing & Distilling (November 9, 2015)

Brewing & Distilling means the *Use* of *Premises* for the *Brewing* or *Distilling* of alcoholic beverages or beverage products with alcoholic content exceeding one percent by volume, where the *Use* may involve the milling of grain, rice, malt or honey licensed under the *Liquor Control and Licensing Act*.

Bylaw 2013-003 added the following definition- Broadcasting Studios (March 11th, 2013):

Broadcasting Studios means development used for the production and/or broadcasting of audio and visual programming typically associated with radio, television and motion picture studios.

Buffer Strip means a landscaped area intended to visibly separate and screen one *Use* from another or to maintain and enhance natural drainage and wildlife movements.

Building means a *Structure* used or intended to be used for sheltering any *Use* which is wholly or partially covered by a roof supported by walls or columns.

Building Permit means the document authorizing the carrying out of any *Development*, alteration or other work in accordance with the Building Regulations Bylaw, the BC Building Code and any other applicable statute or regulation.

Bulk Fuel Depot means a facility for the storage and distribution of fuels and oils which may include key lock operations.

Bylaw 2016-028 amended the following definition – Buoy (October 24, 2016)

Buoy, means a float or similar object that is in turn anchored to the bed of the lake and can be used to moor a water craft.

Business means the *Use* of land for a commercial, industrial or administrative purpose.

Business Support Service means a *Use* which provides support services to *Businesses* and is characterized by the *Use* of minor mechanical equipment for printing, duplicating, binding or photographic processing; secretarial services; *Office* maintenance or custodial services; *Office* security; and the sale and servicing of *Office* equipment, furniture and machines. Typical *Uses* include, but are not limited to, printing establishments, film processing establishments, janitorial firms, *Office* equipment establishments and sign shops.

C

Campground means the *Use* of a *Lot* occupied and maintained for the temporary accommodation of the travelling public in tents and *Recreational Vehicles* but not *Manufactured Housing*.

Canopy means a permanent roof-like *Structure* that extends outwards from a wall or a *Building*. The projection of *Canopies* into required *Setbacks* is regulated in [Section 4.2](#).

Carport means a roofed *Structure* to be used to shelter parked vehicles or equipment which is not enclosed on at least two sides, one being the side fronting the driveway.

Carriage House means a secondary *Dwelling* constructed in an *Accessory Building*. Specific *Use* regulations for *Carriage Houses* are in [Section 7.4](#).

Child Care Centre, Major means a *Use* which provides for the care of more than eight children according to the Child Care Licensing Regulation under the Community Care and Assisted Living Act. Specific *Use* regulations for *Child Care Centres* are in [Section 7.7](#).

Child Care Centre, Minor means the *Use* of a *Dwelling* unit for the care of not more than eight children, according to the Child Care Licensing Regulation under the Community Care and Assisted Living Act. Specific *Use* regulations for *Child Care Centres* are in [Section 7.7](#).

Club means a *Use* which provides for the meeting or social activities of a philanthropic, social service, non-profit, athletic, *Business* or fraternal organization for meetings, or social, educational, or recreational purposes. *Clubs* may include rooms for eating, drinking and general assembly, including incidental catering to the general public.

Commercial Kennel means a *Use* which may include outdoor runs, pens or enclosures for the boarding, breeding and raising of more than three domestic pets for profit or gain but does not include the boarding of animals in a *Veterinary Clinic* during the period of medical treatment.

Commercial Storage means a *Use* in a *Building* or group of *Buildings* providing lockers available for rent to the public for the indoor storage of personal goods.

Community Recreational Service means a *Use* by a not-for-profit organization or government for recreational, social or multi-purpose *Use* without fixed seats, primarily intended for local community purposes. A typical *Use* is a community hall.

Contractor Service, General means a *Use* which provides *Building* and road construction services including concrete, electrical, excavation, drilling, plumbing and heating or similar services of a construction nature which requires either indoor or outdoor storage and warehouse space. Any sales, display, or *Office* areas shall be *Accessory* to the principal *General Contractor Services Use* only.

Contractor Service, Limited means a *Use* which provides for the provision of electrical, plumbing, heating, painting and similar *Contractor Services* primarily to individual households. All required materials used to provide service shall be kept within an enclosed *Building* with no *Accessory* manufacturing activities or fleet storage of more than four vehicles being permitted.

Convenience Store means a *Use* of a *Building* as a retail commercial establishment, not exceeding 150m² in *Gross Floor Area*, which supplies groceries and other daily household necessities to area residents or employees. Typical *Uses* include, but are not limited to, foodmarts, drugstores and variety stores.

D

Deck means an outdoor seating area supported by the ground being more than 0.6m above *Finished Grade* with no walls except for privacy partitions and railings. The projection of *Decks* into required *Setbacks* is regulated in [Section 4.2](#).

Density means the total amount of floor space permitted to be constructed on a *Lot* under the *Floor Area Ratio* calculation.

Derelict Motor Vehicle means any inoperative motor vehicle which is not licensed.

Development means any *Use* or change in *Use*, construction, building, erection, installation, repair, alteration, addition, enlargement, reconstruction, demolition, removal, excavation or moving, locating, relocating, shoring to which the *District's* Building Bylaw applies or for which Development Permit Approval is required.

Development Site means an area of land consisting of a *Lot* or two or more *Abutting Lots*.

District means the Corporation of the District of Summerland.

District Official means the official or officials appointed by the *District Council* to administer and enforce the provisions of the BC Building Code, the *District's* Building Regulations Bylaw and this Bylaw and includes a Building Inspector.

Bylaw 2016-028 amended the following definition – Dock (October 24, 2016)

Dock, means a structure extending over the water, either floating or fixed to the lake bed that is connected to the shoreline and can be used as a landing or wharfage place for water craft.

Dormer means a structural element of a *Building* that protrudes from the plane of a sloping roof to add headroom to a *Loft*. This does not include a single *Dormer* that is wider than 30 percent of the roof length or multiple *Dormers* that collectively are wider than 50 percent of the roof length.

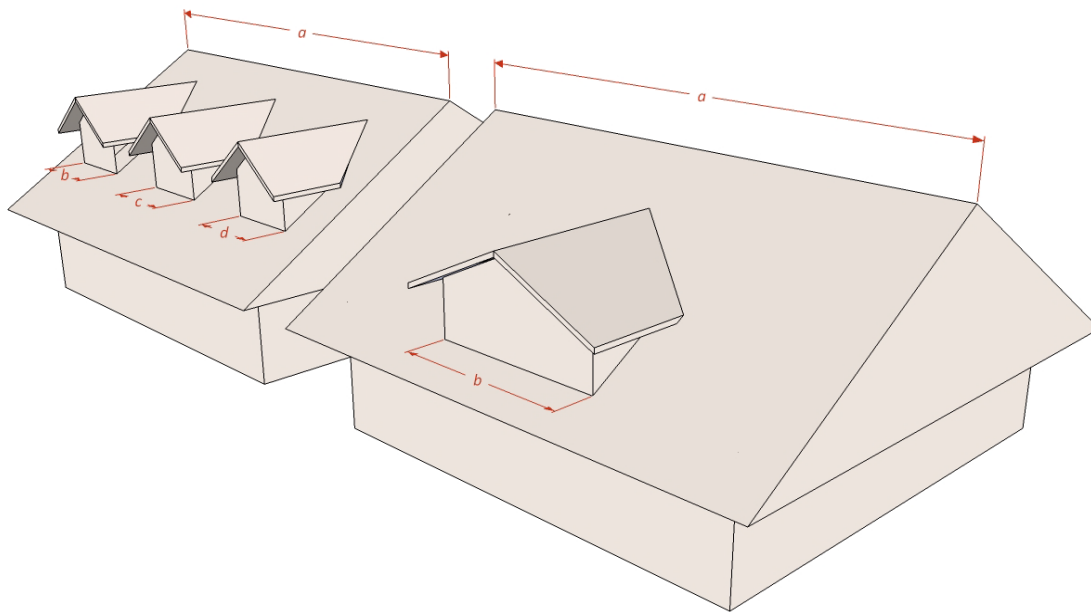

Dormer

$$b+c+d < 50\% \text{ of } a \mid b < 30\% \text{ of } a$$

Bylaw 2017-021 added the following definition – Dormitory (August 28, 2017)

Dormitory means a building containing sleeping units for occupancy by student or staff affiliated with an institution that is primarily of a non-commercial nature and which is regulated by such institution. A dormitory may contain communal kitchen facilities but shall exclude the preparation of meals within individual sleeping units.

Dwelling means one or more rooms which constitute a self-contained unit used or intended to be used for living and sleeping purposes and includes one *Kitchen* or the services for the installation of a *Kitchen* and at least one bathroom with a water closet, sink, shower or bath. This does not include a sleeping unit, *Motel* or *Hotel*. A *Dwelling* may contain a *Bar*.

Dwelling, Additional for Farm Help means a second *Dwelling* located on a *Lot* where full time employee(s) are required to operate an *Agricultural Use*, due to the intensity of farming as

identified by a professional agrologist in a written report or as identified through a letter from the *Agricultural Land Commission*.

E

Eating & Drinking Establishment means a *Use* where food and/or beverages are offered to the public for consumption within the *Premises* or off site. Typical *Uses* include, but are not limited to, restaurants, dairy bars, coffee shops, delicatessens, and licensed drinking establishments.

Education Service means a facility for instruction and education. Typical *Uses* include, but are not limited to, public and separate schools, language schools, art schools, community colleges, universities and technical, trade and vocational schools.

Equipment Rental means a *Use* which provides for the storage and rental of tools, appliances, *Office* machines, furniture and construction equipment, but does not include the rental of motor vehicles.

F

Farm Home Plate means the portion of a *Lot* that includes a farm residence and *Accessory Buildings* and *Structures* related to residential usage.

Fence means a constructed barrier of any material or combination of materials erected vertically to provide visual screening or prevent vehicular or pedestrian access. A *Fence* does not include trees, a *Landscaped Strip*, a landscape screen, or a retaining wall.

Financial Service means a *Use* provided by a bank, trust company, , credit union, or related *Business*.

Fleet Service means the *Use* of a *Lot* for a fleet of vehicles for the delivery of persons, goods or services where such vehicles are not available for sale or long term lease. Typical *Uses* include, but are not limited to, messenger services, courier services and taxi operations.

Floor Area, Gross means the total floor area of all *Storeys* of all *Buildings* or *Structures* with a clear ceiling *Height* of 1.8m or more, measured from the inside face of the exterior walls or glazing line of windows. The *Gross Floor Area* maximum does not include *Carriage Houses* and enclosed or covered off-*Street* parking areas up to 46m² in area, enclosed garbage or refuse areas, enclosed off-*Street* loading spaces, floor areas devoted exclusively to mechanical or electrical equipment, *Basements*, *Lofts*, unenclosed *Balconies* and *Decks* and interior stairways.

Floor Area Ratio (FAR) means the quotient of the *Gross Floor Area* of all *Buildings* or *Structures* on a *Lot* divided by the *Lot Area* in the RSD1(i), RSD1, RSD2, RSD3 and RDH zones; and divided by the *Net Lot Area* in all other zones, of that *Lot*.

Foreshore means the Crown-owned land located between the high and low water marks of a stream, river or lake.

Frontage means the common boundary shared by a *Property Line* and a *Street*. On a *Corner Lot* or *Through Lot*, the shortest *Property Line* shall be deemed the *Frontage*.

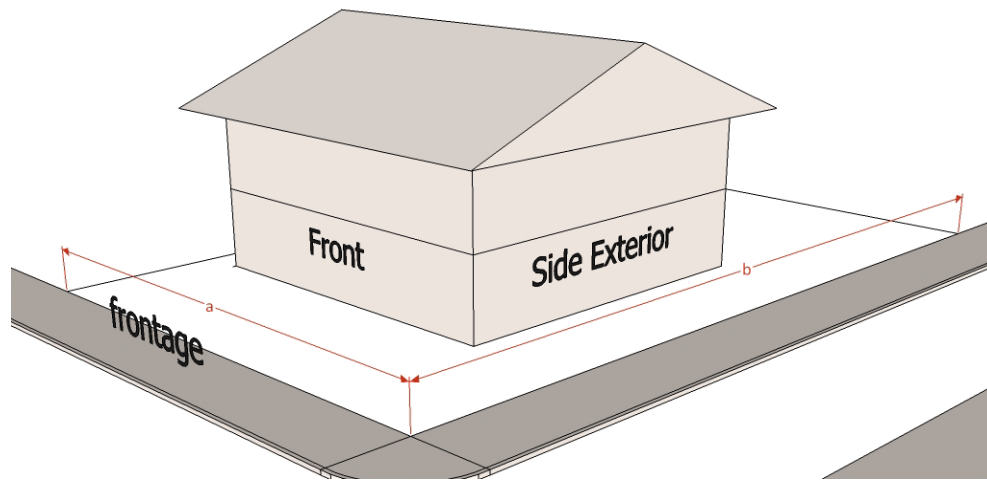

Frontage
 $a < b$, therefore $a = \text{Frontage}$ and $b = \text{Exterior Side}$

Funeral Home means a *Premises* used for the preparation of the dead for burial or cremation and the holding of funeral services, but shall not include facilities for cremation.

G

Gas Bar means a *Use* which provides for the sale of motor fuels, lubricating oils and vehicle fluids and may contain a *Convenience Store* but does not include any facility for the servicing, repair or maintenance of vehicles.

Bylaw 2013-008 amended the following definition (General Industrial Use)- (April 29th, 2013):

General Industrial Use means a *Use* which provides for the manufacturing, processing, assembling, fabricating, storing, transporting, distributing, testing, servicing or repairing of goods, materials, or things, excluding abattoirs and the processing of concrete and asphalt, and may include *Accessory Office* and *Retail Store Uses*. Typical *Uses* include, but are not limited to, processing of new materials, the manufacturing or assembly of semi-finished or finished goods, products or equipment; the storage, cleaning, servicing, repairing or testing of materials, goods and equipment; terminals for the storage of transshipping of materials, goods and equipment; and the distribution and sale of materials, bulk goods and equipment to *Businesses* for their own *Use* or resale to the general public at other locations.

Government & Utility Service Use means a *Use* which provides for the essential utility servicing of the *District* with water, sewer, electrical, natural gas, telephone, and/or similar utilities where such utilities are established by the *District*, by another government body or by a company operating under the Public Utilities Act. This *Use* does not include *Storage Yards*.

Grade means the elevation of the land measured from the lower of *Natural Grade* or *Finished Grade* adjoining the exterior wall of a *Building*.

Grade, Average Building, for the purpose of determining the *First Storey* of a *Building* or *Structure*, means the mathematical average of *Grade* measured at each of the outermost exterior corners of a *Building*.

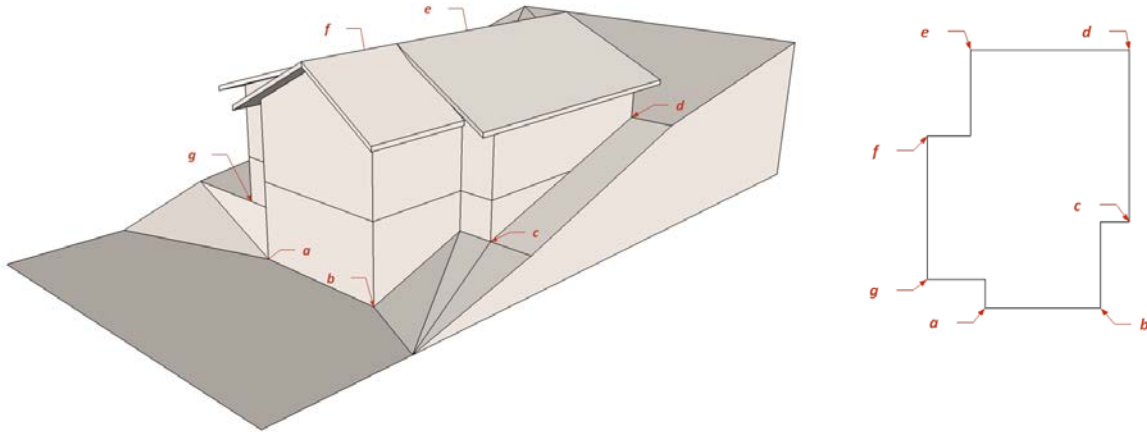

Average Building Grade
Average Building Grade = average (a,b,c,d,e,f,g)

Grade, Building, for the purposes of determining the *Height* of a *Building* or *Structure*, means the lowest of the mathematical average of *Grade* for each wall segment of a *Building* or *Structure*, as measured at each corner of a *Building*.

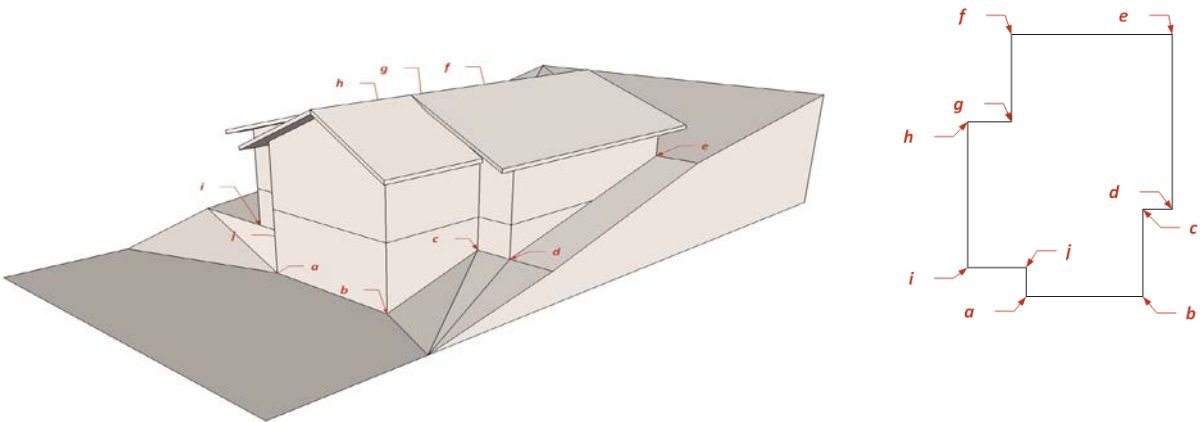

Building Grade
Building Grade = the lowest of average(a,b), average(b,c), average(c,d), ... average(j,a)

Grade, Finished, with reference to a *Building*, *Structure*, or *Landscaping*, means the elevation of the finished ground at any point adjoining each exterior wall of a *Building*, *Structure*, or *Landscaping*.

Grade, Natural, with reference to a *Building* or *Structure* not requiring subdivision, means the elevation of the ground surface in its existing state, prior to any disturbance, alteration, excavation or filling; whereas with reference to any *Development* requiring subdivision, means the elevations shown on the grading plan where such a plan has been approved by the *District* at the time of subdivision when the *Lot* was created.

Group Home, Major means the *Use* of land, *Buildings*, and *Structures* for the provision of care, as defined by the Community Care and Assisted Living Act, for more than six residents, excluding staff, which are vulnerable because of family circumstances, age, disability, illness or frailty, and are dependent on caregivers for continuing assistance or direction. Specific *Use* regulations for *Group Homes* are in [Section 7.8](#).

Group Home, Minor means the *Use* of a *Single Detached House* for the provision of care, as defined by the Community Care and Assisted Living Act. The character of the *Use* is that the occupants live with the facility operators as a single household group using a common *Kitchen*. Specific *Use* regulations for *Group Homes* are in [Section 7.8](#).

H

Hard Surfacing means a durable ground surface, constructed of cast-in-place concrete, brick or concrete unit pavers, turfstone, asphalt or similar materials but excludes gravel, sand and clay.

Health Service means the provision of physical and mental *Health Services* on an outpatient basis. Typical *Uses* include, but are not limited to, medical and dental *Offices*, chiropractic *Offices*, health clinics and mental health counselling services.

Bylaw 2012-017 amended the following definition of Height (July 23rd, 2012)

Height, when used with reference to a *Building* or *Structure*, means the vertical distance measured from *Building Grade* to the higher of:

- (a) highest point of a flat roof; or a roof with a pitch less than 4 in 12;

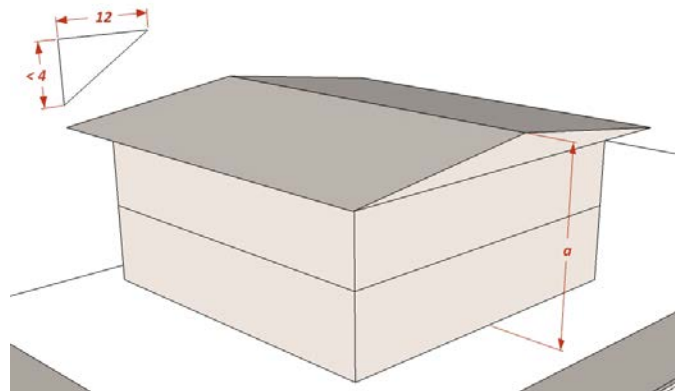

Height = a, where: Roof pitch < 4 in 12

- (b) the mean level between the eaves and ridge of a roof with a pitch greater than or equal to 4 in 12, provided the ridge does not extend more than 2.4m above the mean level; or

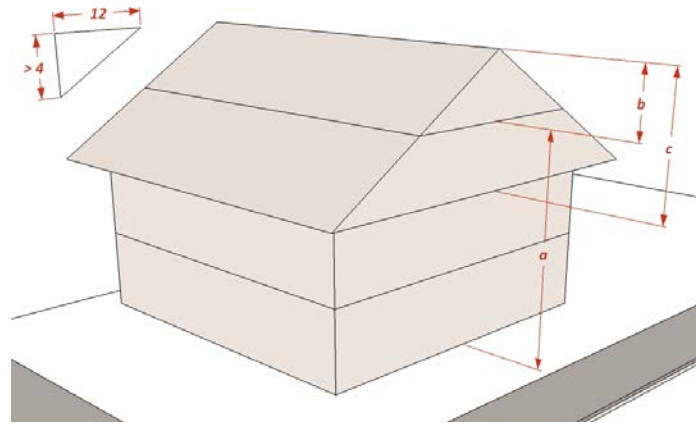

Height = a , where: Roof pitch > 4 in 12 and $b = \frac{1}{2}$ of c and $b < 2.4\text{m}$

- (c) in the case of a *Structure* without a roof, the highest point of that *Structure*.

Highway means a public *Street*, road, or other public way which provides principal access to a *Lot*.

Bylaw 2000-459 amended the following definition (November 14, 2011):

Home Occupation means an occupation, *Business*, or professional practice conducted for remuneration and contained entirely within a *Dwelling* or its *Accessory Buildings* which is clearly subordinate to the *Principal Use* as a *Dwelling* and where the proprietor is also a resident of the *Dwelling* where the *Home Occupation* occurs. This does not include *Uses* such as *Automotive & Equipment Repair Shops*, *Autobody Repair Shops*, *Eating & Drinking Establishments*, *Commercial Kennels*, *Veterinary Clinics*, *Animal Shelters*, *Group Homes*, *Child Care Centres* or *Health Services*. Specific *Use* regulations for *Home Occupations* are in [Section 7.6](#).

Hotel means a *Use* which provides exclusively for the temporary accommodation of the travelling public. Access to guestrooms is by way of interior corridors connected to a main lobby that contains a central check-in facility. The *Hotel* may include *Eating & Drinking Establishments*, banquet/meeting rooms, *General Retail Stores* or boutiques, beer and wine stores, personal service facilities and *Indoor Recreational Services* or fitness centres.

Bylaw 2013-003 amended the following definition- Housing, Apartment (March 11th, 2013):

Housing, Apartment means a *Building* comprised of more than four *Dwellings* which have principal access from a common interior corridor, and which are not *Townhouses*.

Housing, Cluster means the construction of more than one *Dwelling* on a *Lot* whereby the *Dwellings* are concentrated to specific areas on a *Lot* to allow a portion of the *Lot* to be used for

recreation, open space, or preservation of natural, historical, cultural, or other similar type of amenity. A covenant limiting *Development* on the remaining portion of the Lot may be required by the *District*.

Housing, Duplex means a *Building* containing two *Dwellings* divided horizontally or vertically by a common party wall, and each *Dwelling* having a separate, but not necessarily at *Grade*, exterior entrance. This does not include *Secondary Suites*.

Housing, Employee means a *Dwelling* unit *Accessory* to a non-agricultural *Principal Use*, intended for occupation by an employee of the *Principal Use*, such as a manager, watchman, or caretaker.

Housing, Manufactured means a *Building* containing one *Dwelling* for occupancy by one household, built in a factory environment in one or more sections, intended to be occupied in a place other than its manufacture. All manufactured homes shall be constructed to either the CAN/CSA A277 (Modular Home) standard or CAN/CSA Z240 (Mobile Homes).

Housing, Manufactured - Type 1 means a manufactured home constructed to the CAN/CSA A277 (Modular Homes) standard, built in two or more sections to be assembled on a permanent foundation in accordance with the BC Building Code.

Housing, Manufactured - Type 2 means a manufactured home constructed to the CAN/CSA Z240 (Mobile Home) standard, capable of being moved from place to place and which conforms to the BC Building Code or the CSA Z240.10.1 standard including skirting.

Housing, Manufactured Community means the *Use* of the land for more than two *Manufactured Housing Lots* either individually owned or leased.

Housing, Manufactured Lot means any surveyed or unsurveyed *Lot*, which has been shown on a plan or title to be occupied or intended to be occupied by a manufactured house, within a *Manufactured Housing Community*.

Housing, Single Detached means a *Building* containing one *Dwelling*. A *Secondary Suite* can be included in *Single Detached Housing* where specifically defined as an *Accessory Use* in this Bylaw. *Housing, Single Detached* does not include *Manufactured Housing - Type 2*.

Housing, Townhouse means a *Building* containing more than two *Dwellings* where each *Dwelling* shares at least one party wall, and each *Dwelling* has a separate, but not necessarily at *Grade*, entrance.

Bylaw 2013-003 added the following definition- Industrial High Technology Research and Product Design (March 11th, 2013):

I

Industrial High Technology Research and Product Design means the research and/or design, including the manufacture and/or distribution, of products used in the fields of computer software and programming, electronics, telecommunications, aeronautics, precision engineering, robotics, biochemistry, health care, and related industries. Related Industries may include business services such as data storage, provision of server space, and servicing of

computer equipment. This use may include up to 25% of the space to be used for an office component.

K

Kitchen means facilities intended or used for the preparation or cooking of food, and includes any room or portion of a room containing cooking appliances including, without limitation, stoves or ovens. Plumbing or wiring or provision for a stove or oven constitutes the existence of such appliances.

L

Landscaped Screen means a landscaped area used to screen and buffer land *Uses* and is comprised of a dense planting of evergreen vegetation which has a minimum *Height* of 1.2m at the time of planting and may only be broken for driveways and *Walkways*.

Landscaped Strip means a landscaped area used to physically separate differing land *Uses* and meets the following specifications:

- (a) trees shall be planted at a maximum spacing of 5.0m on centre and shall be a minimum of 2.0m in *Height* at time of planting;
- (b) shrubs and ground cover shall be provided for a minimum of 50 percent of the *Landscaped Strip* area;
- (c) shrubs shall be planted at a maximum spacing of 1.0m on centre and shall be a minimum 2.0 gallon pot size at time of planting; and
- (d) the *Landscaped Strip* may be broken only for driveways and *Walkways*.

Landscaping means changing, modifying or enhancing the visual external appearance of a *Development* including reshaping the earth, planting vegetation, adding walks, *Patios*, *Fencing* or other ornamental features, and includes the retention of existing trees and plants where appropriate. This does not include *Hard Surfaced* areas for vehicle parking or the alteration of a site for the purposes of determining *Average Building Grade*. *Landscaping* regulations are in [Section 5](#).

Live-Work Unit means a *Premise* where a principal commercial *Use* is permitted, including but not limited to, an artisan *Use*, professional consulting, barber shops, beauty salons, acupuncture clinics, massage therapists, tailors, dress makers, and shoe repair shops, and where an owner or employee of said *Principal* commercial *Use* is permitted to occupy a *Dwelling* within that same *Premise*.

Loft means an open space located wholly within a sloping roof of a residential *Dwelling*.

Lot means any parcel, block or other area in which land is held or into which it is subdivided, but does not include a *Highway*.

Lot Area means the total horizontal area within the *Property Lines* of a *Lot*.

Lot Area, Net means, unless defined elsewhere in this Bylaw, the total area of a *Lot* excluding any area of the *Lot* which exceeds a 30 percent slope or has been protected as an environmentally sensitive area by a Section 219 covenant or *Development* permit.

Lot, Corner means a *Lot* situated at the intersection of two or more *Streets*, or a *Lot Abutting* a *Street* which substantially changes direction at any point *Abutting* that *Lot*.

Lot Coverage means the percentage of the *Lot Area* in the RSD1(i), RSD1, RSD2, RSD3 and RDH zones; and percentage of the *Net Lot Area* in all other zones, that may be built upon including *Accessory Buildings* or *Structures* (including *Carports*, covered *Patios* and *Decks* larger than 23m²) excluding steps, eaves, cornices, cantilevered *Balconies* and similar projections.

Lot Depth means the horizontal distance measured between the midpoints of the *Front* and *Rear Property Lines*.

Lot, Through means a *Lot* bounded on two opposite sides by a *Street*.

Lot Width means the horizontal distance of a *Lot* measured between the *Side Property Lines* at the minimum *Front Setback*.

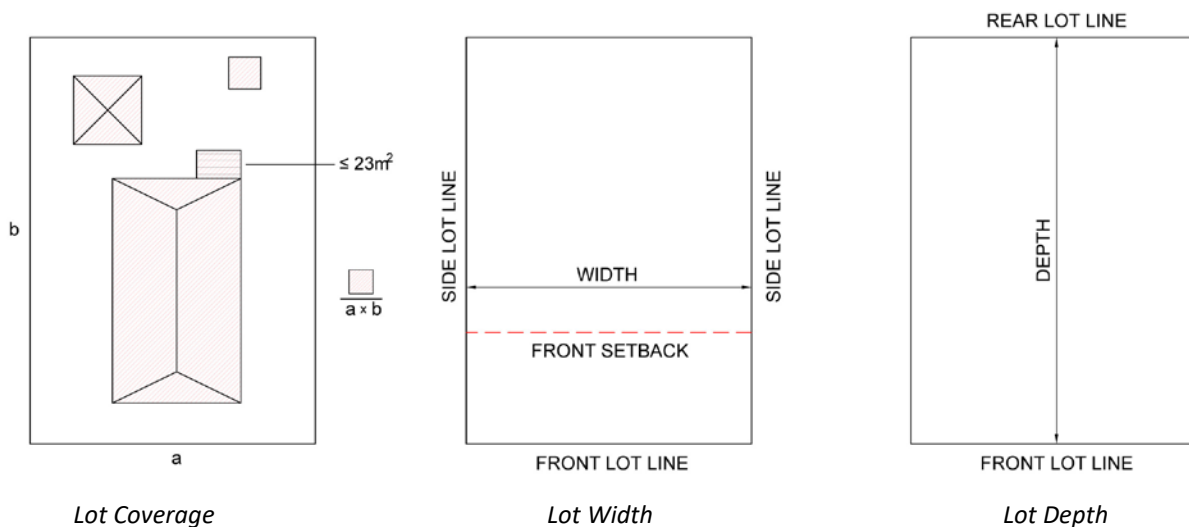

M

Manager of Development Services, or successors in title, means a person appointed by Council to administer this Bylaw.

Marina means a commercial or public establishment, containing docking facilities or mooring facilities where boats and other water vessels are berthed, stored, serviced, constructed or kept for sale or rent. Facilities for the sale of marine fuels, lubricants, and liquids; accessory boating retail sales; and wastewater pumping facilities may also be provided.

Motel means a *Use* which provides exclusively for the temporary accommodation of the travelling public. Access to each guestroom is directly from the outside and the required parking is located at *Grade*. Each guestroom may include a *Kitchen*. The *Motel* may also include indoor or outdoor pools, an *Eating & Drinking Establishment*, and *Employee Housing*.

Bylaw 2016-028 amended the following definition – Moorage (October 24, 2016)

Moorage, means the tying of a water craft to a buoy.

N

Natural Boundary means the visible high water mark of any lake, river, stream or other body of water where the presence and action of the water are so common and visual, and so long continued in all ordinary years as to mark the soil of the bed of the body of water and also includes the edge of dormant side channels of any lake, river, stream or other body of water.

Natural Resource Extraction includes the quarrying, processing, removal and sale of sand, gravel, earth or mineralized rock found on or under the *Lot*.

O

Office means a *Use* which provides for the provision of professional, management, administrative or consulting services in an *Office* setting. Typical *Uses* include, but are not limited to, the *Offices* of lawyers, accountants, travel agents, real estate and insurance firms, investment planners, clerical and secretarial agencies. This *Use* does not include *Financial Services*.

P

Parking Lot means a *Use* of a *Building* or *Lot* or part of a *Lot* for the temporary parking of more than one vehicle by customers, residents, employees and/or the public at large.

Parking Space means an off-*Street* space of the size and dimensions to park one vehicle in conformance with [Section 6](#) of this Bylaw exclusive of driveways, aisles, loading spaces, ramps or obstructions.

Patio means a surfaced open space meant for support of people or materials, located at or less than 0.6m above *Finished Grade*. The projection of *Patios* into required *Setbacks* is regulated in [Section 4.2](#).

Personal Service Establishment means a *Use* which provides personal services to an individual which are related to the care and appearance of the body or the cleaning and repair of personal effects. Typical *Uses* include, but are not limited to, barber shops, beauty salons, acupuncture clinics, massage therapists, tailors, dress makers, shoe repair shops, laundry and dry cleaning establishments but do not include *Health Services*.

Place of Worship means a *Use* by members of a religious faith for meetings, study and worship and may include manses or rectories and recreational, social, charitable, philanthropic, cultural, or educational activities.

Porch means a roofed *Structure* projecting from the exterior wall of a *Building* with walls which open or are screened to facilitate *Use* as a seasonal outdoor living area. The projection of *Porches* into required *Setbacks* is regulated in [Section 4.2](#).

Premise means that part of a *Building* being used to carry on a *Business*.

Principal Use means the main or primary *Use* of land, *Buildings* or *Structures* which is provided for in the list of permitted *Principal Uses* in the zones of this Bylaw.

Property Line means a legal boundary of a *Lot*.

Property Line, Exterior Side means a *Property Line* other than a *Front* or *Rear Property Line* and is separating the *Lot* from the *Flanking Street* or across route in a bare land strata plan.

Bylaw 2014-017 amended the following definition- *Property Line, Front* (August 25th, 2014):

Property Line, Front means the *Property Line* separating the *Lot* from the *Street* and in the case of a *Corner Lot* either *Property Line* separating the *Lot* from the *Street* may be deemed the *Front Property Line*; and in the case of a *Through Lot* the *Front Property Line* shall be determined by prior common practice in the area.

Property Line, Interior Side means a *Property Line* other than a *Front, Rear, or Exterior Side Property Line*.

Property Line, Rear means the *Property Line* or point of intersection of the *Side Property Lines* farthest from and opposite to the *Front Property Line*.

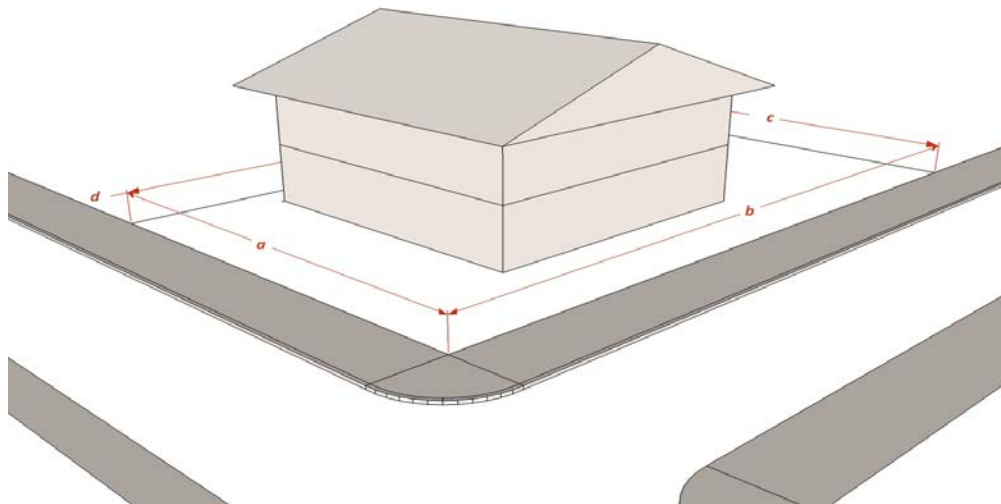

Property Lines

*a = Front Property Line; b = Exterior Side Property Line;
c = Rear Property Line; d = Interior Side Property Line*

Protective and Emergency Service means a *Use* which provides emergency services to the general public. Typical *Uses* include, but are not limited to, fire, police and ambulance stations.

R

Recreation, Openland means a *Use* of a natural landscape for low-impact recreational activities that are consistent with the preservation and protection of natural areas in the community and includes the *Development* of trails.

Recreational Service, Indoor means a *Use* contained wholly within an enclosed *Building* for sports and active recreation where patrons are predominantly participants. Typical *Uses* include, but are not limited to, athletic *Clubs*, health and fitness *Clubs*, swimming pools, curling *Clubs*, hockey rinks and racquet *Clubs*.

Recreation Service, Outdoor means a *Use* available to the general public for sports and active recreation conducted outdoors. Typical *Uses* include, but are not limited to, golf courses, ball fields, athletic fields, and lawn bowling facilities.

Recreational Vehicle means a vehicle which provides sleeping and other facilities for short periods of time while travelling or vacationing, designed to be towed behind a motor vehicle or self-propelled, and which includes such vehicles commonly known as tent trailers, travel trailers, campers, coaches, motorized homes or other similar vehicles.

Recycle Drop-Off Centre means a *Use* which provides for the collection and temporary storage of recyclable materials which are periodically removed and taken to a permanent recycling facility for final processing. This does not include *Recycling Depots*.

Recycling Depot means a *Use* which provides for the buying, collecting, sorting and temporary storage of bottles, cans, newspapers and similar household goods for reuse where all storage is contained within an enclosed *Building*. This does not include *Recycle Drop-Off Centres*.

Retail Store, General means a *Use* where goods, merchandise and other materials are offered for sale at retail to the general public. Typical *Uses* include, but are not limited to, grocery, hardware, pharmaceutical, appliance and sporting goods stores. This *Use* excludes warehouse sales, sale of gasoline, heavy agricultural and industrial equipment sales.

S

Secondary Suite means a self-contained, second *Dwelling* located within a *Single Detached House* and having a separate outside entrance. This *Use* does not include *Duplex Housing*, *Townhouses*, or *Carriage Houses*. Specific *Use* regulations for *Secondary Suites* are in [Section 7.3](#).

Service Station means a *Use* which provides for the servicing, washing or maintenance of vehicles, and the sale of motor fuels and lubricants, other vehicle petroleum products, and a limited range of vehicle parts and accessories. Specific *Use* regulations for *Service Stations* are in [Section 7.9](#)

Setback, Front means that portion of a *Front Yard* between the *Front Property Line* and a parallel *Front Setback Line* which intersects the two *Side Property Lines* at such position that the shortest distance measured perpendicular from the *Setback* line to the *Front Property Line* is equal to the

minimum distance required for the *Front Setback* of a principal *Building* under this Bylaw. Where the front face of a principal *Building* *Abuts* the *Front Setback Line*, it shall be measured at the outside edge of the footing of the *Building* foundation wall.

Setback, Rear means that portion of a *Rear Yard* between the *Rear Property Line* and a parallel *Rear Setback Line* which intersects the two *Side Property Lines* at such position that the shortest distance measured perpendicular from the *Setback Line* to the *Rear Property Line* is equal to the minimum distance required for the *Rear Setback* of a principal *Building* under this Bylaw. Where the rear face of a principal *Building* *Abuts* the *Rear Setback Line*, it shall be measured at the *Building* foundation wall.

Setback, Side means that portion of a *Side Yard* between the *Exterior* or *Interior Side Property Line* and a parallel *Exterior* or *Interior Side Setback Line* which intersects the *Front* and *Rear Property Lines* at such position that the shortest distance measured perpendicular from the *Setback Line* to the *Exterior* or *Interior Side Property Line* is equal to the minimum distance required for the *Exterior* or *Interior Side Setback* of a principal *Building* under this Bylaw. Where the side face of a principal *Building* *Abuts* the *Exterior* or *Interior Side Setback Line*, it shall be measured at the *Building* foundation wall.

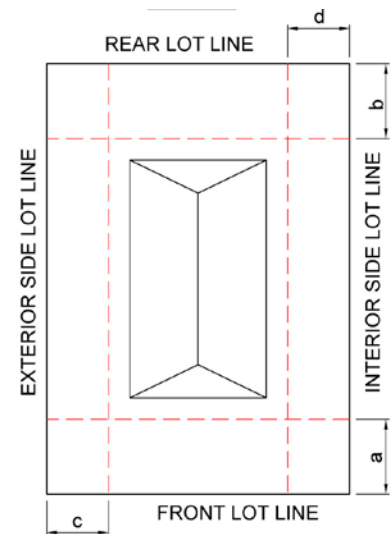

Setbacks

a = Front Setback

b = Rear Setback

c = Exterior Side Setback

d = Interior Side Setback

Shopping Centre means a *Use* whereby one or more *Buildings* containing more than six *Premises* exceeding 2,500m² of *Gross Floor Area* share common services, parking and other facilities on one or more *Lots*.

Site Triangle means the triangular space formed by the *Front* and *Exterior Side Property Lines* of a *Corner Lot* and a line drawn from a point on one *Property Line* to a point on the other *Property Line*, each such point being 7.0m from the point of intersection of the *Property Lines*. *Landscaping* within the *Site Triangle* is regulated in [Section 5.3.1](#).

Storage Yard means a *Use* which provides for the outdoor storage of equipment, goods and materials where such storage of goods and materials does not always involve the erection of permanent *Buildings* or *Structures* or require major alterations to the existing state of the land. Typical *Uses* include, but are not limited to, pipe yards, contractor yards or utility works yards.

Storey means that part of a *Building* other than a *Basement* or *Loft* which is situated between the top of any floor and the top of the next floor above it and if there is no floor above it, that portion between the top of such floor and the ceiling above it.

Storey, First means the lowest *Storey* which has a finished floor elevation not more than 1.2m above the *Average Building Grade*.

Street means a *Highway* other than a lane which affords the principal access to a *Lot*.

Street, Flanking means a *Street* that *Abuts* an *Exterior Side Property Line*.

Structure means a construction of any kind whether fixed to or supported by or sunk into land or water including, but not limited to, towers, flag poles, swimming pools, docks, signs and tanks, but excluding areas of *Hard Surfacing*.

T

Tandem Parking means two *Parking Spaces*, one behind the other, with a common or shared point of access to a driving aisle or *Highway*.

Temporary Farm Worker Accommodation means a *Use* within a *Building* designed specifically for seasonal farm workers to live in for short periods of time during the harvest season. *Buildings* constructed for this *Use* must contain sleeping facilities and may contain washroom facilities but may not contain cooking facilities.

Theatre means a *Use* contained wholly within an enclosed *Building* designed specifically for the presentation of live performances or the showing of motion pictures. Typical *Uses* include, but are not limited to, cinemas, and performing art and concert halls.

U

Urban Services, Full means the provision of utility infrastructure consisting of a community water system, a community sanitary sewer collection system, an *Abutting* paved *Street* and electrical and/or gas connection capabilities.

Use means the purposes for which land or a *Building*, or a *Structure* is arranged or intended, or for which either land, a *Building*, or a *Structure* is, or may be, occupied and maintained.

V

Bylaw 2000-459 replaced the following definition (November 14, 2011):

Veterinary Clinic means a *Use* which provides for the medical and surgical treatment for domestic pets, animals and birds which shall include indoor short-time boarding of pets during the period of medical treatment.

W

Walkway means a right-of-way intended to accommodate pedestrian movements, except that a *Walkway* may be designed to accommodate occasional access for emergency vehicles.

Warehouse Sales Establishment means a *Use* which provides for the wholesale or retail sale of a limited range of bulky goods from within an enclosed *Building* where the size and nature of the principal goods being sold typically require large floor areas for direct display to the purchaser or consumer. Typical *Uses* include, but are not limited to, the sale of furniture, carpet, major

appliances, and building materials. This *Use* does not include a *General Retail Store* or an *Eating or Drinking Establishment*.

Bylaw 2016-028 amended the following definition – Water craft (October 24, 2016)

Water craft, means a motor boat, sail boat, jet ski, canoe, kayak or other means of transportation supported by water.

Watercourse means any natural depression with visible banks, which contains water at some time, and includes any lake, river, stream, creek, spring, ravine, swamp, gulch, coulee, wetland, or surface source of water, whether containing fish or not, including intermittent streams, and drainage works which contain fish.

Bylaw 2016-028 amended the following definition – Wharfage (October 24, 2016)

Wharfage, means the tying of a water craft to a dock.

Winery & Cidery means a British Columbia winery or cidery, licensed under the Liquor Control and Licensing Act.

Wrecking Yard means a *Use* which provides for the collection, demolition, dismantlement, storage, salvage, recycling or sale of waste materials including scrap metal, vehicles, parts, machinery and other discarded materials.

Y

Yard, Front means that part of the *Lot* which extends across the full width of the *Lot* located between the *Side Property Lines* extending from the *Front Property Line* to the nearest wall or supporting member of a principal *Building* or *Structure*.

Yard, Rear means that part of the *Lot* which extends across the full width of the *Lot* located between the *Side Property Lines* extending from the *Rear Property Line* to the nearest wall or supporting member of a principal *Building* or *Structure*.

Yard, Side means that part of the *Lot* which extends from a *Front Yard* to the *Rear Yard* between the *Side Property Line* of a *Lot* and the nearest wall or supporting member of a principal *Building* or *Structure*.

Yard, Side Interior means a *Side Yard* other than an *Exterior Side Yard*.

Yard, Side Exterior means a *Side Yard* Abutting a *Street*.

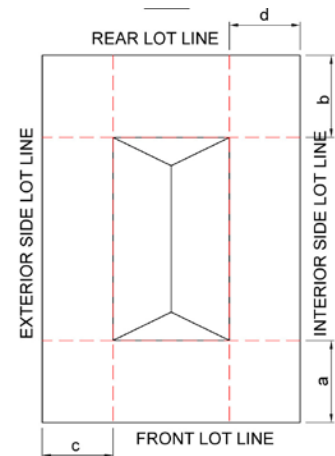

Yards

a: Front Yard

b: Rear Yard

c: Exterior Side Yard

d: Interior Side Yard

3.0 Establishment of Zones

3.1 Establishment of Zones

3.1.1 The area of the District of Summerland shall be divided into zones identified in Column 2 of Table 3.1.

3.1.2 The correct name of each zone provided for in this Bylaw is set out in Column 2 of Table 3.1 with the corresponding general zoning category contained in Column 1 of the same Table.

Bylaw 2016-028 amended table 3.1 by adding Water Zones (October 24, 2016)

Table 3.1: Establishment of Zones

Column 1	Column 2
Agricultural Zones	A1 Agricultural Small Acreage Zone A2 Agricultural Large Acreage Zone
Rural Residential Zones	CR1 Country Residential Zone
Urban Residential Zones	RSD1 Residential Medium Lot Zone RSD2 Residential Large Lot Zone RSD3 Residential Estate Lot Zone RDH Residential Duplex Housing Zone RSH Residential Strata Housing Zone RMD Residential Medium Density Zone RHD Residential High Density Zone RMH Residential Manufactured Housing Zone
Commercial Zones	CN Neighbourhood Commercial Zone CT1 Tourist Commercial Zone CH Highway Commercial Zone CT2 Campground Zone CB1 Central Business Zone CB2 Shopping Centre Zone CM Heavy Commercial Zone

Industrial Zones	M1 Light Industrial Zone M2 Heavy Industrial Zone M3 Agri-Industrial Zone M4 Resource Industrial Zone
Parks, Openland and Institutional Zones	PR1 Parks and Recreation Zone FG Forestry Grazing Zone PP Preservation & Protection Zone I Institutional Zone
Site Specific	CD Comprehensive Development Zone
Water Zones	WZ1 Recreational Water Use Zone 1 WZ2 Recreational Water Use Zone 2 WZ3 Intensive Water Use Zone

3.2 Zone Boundaries

3.2.1 The location of each zone is defined on Schedule “B” of this Bylaw entitled “District of Summerland Official Zoning Map” which is attached to and forms part of this Bylaw.

3.2.2 The boundaries of a zone shown on Schedule “B” shall be interpreted as follows:

- (a) where the zone boundary follows a *Highway*, pipeline, powerline, utility right-of-way, railway line, or easement, it follows the centreline, unless otherwise clearly indicated on the map;
- (b) where the zone boundary is shown as approximately following the *District* boundary or a *Property Line*, it follows the *District* boundary or *Property Line*;
- (c) where the zone boundary is shown as following a topographic contour line or a geographic feature, it follows that line. In the event of change of the topographic contour line or geographic feature, it shall move with that line;
- (d) where the zone boundary is shown as approximately following the edge of a *Natural Boundary* of a *Watercourse*, it follows the *Natural Boundary*. In the event of change in the *Natural Boundary* of a *Watercourse*, it shall move with the *Natural Boundary*;
- (e) where a zone boundary is shown as approximately following the *Agricultural Land Reserve* boundary, it follows that boundary; and
- (f) in circumstances not covered by any of the above statements, the zone boundary shall be determined by scaling the zoning map.

3.3 Undersized Lots

- 3.3.1 Where a *Lot* is reduced in size as a result of taking for public *Use* by the *District*, provincial or federal government, or a public utility by dedication, expropriation, or purchase, the *Lot*, *Buildings* and *Structures* thereon are deemed to conform with the provisions of this Bylaw and the *Lot* shall be considered to exist as it did prior to the taking.

3.4 Uses and Regulations

- 3.4.1 Subject to Section 3.3.1, all *Uses*, *Buildings* and *Structures* in each zone shall be in accordance with the *Uses* and regulations applying in that zone, as well as all other regulations and requirements of the Bylaw.

4.0 General Regulations

4.1 Uses Permitted in All Zones

4.1.1 The following *Uses* are permitted in all zones:

- (a) *Government and Utility Service Uses*;
- (b) Highways;
- (c) parks;
- (d) conservation areas; and
- (e) *Urban Agriculture*.

4.2 Projections into Setbacks

Bylaw 2015-009 amended the following 4.2.1(c) adding 'above grade patios' – adopted May 11th, 2015.

4.2.1 No *Building* or *Structure* other than the following shall be located in the *Setbacks* required in this Bylaw. This section is not applicable to the setbacks stated in Section 4.7.1 – Setbacks from Highways and Major Streets:

- (a) chimneys, cornices, leaders, eaves, gutters, pilasters, belt courses, sills, bay windows and similar features may project into a required *Setback* provided such projections do not exceed 0.6m measured horizontally (*a, b, c, and d* in the figure below);
- (b) fencing and retaining walls subject to the regulations of this Bylaw;
- (c) unenclosed *Decks, above grade patios, Balconies, Porches* or steps, eaves, *Canopies* and *Awnings* may project into a required *Setback* provided such projections do not exceed 1.5m in the case of a *Front Yard* or an *Exterior Side Yard* (*b* and *c* in the figure below); 0.6m in the case of an *Interior Side Yard* (*c* in the figure below); or 2.0m in the case of a *Rear Yard* (*d* in the figure below);
- (d) ramps providing an accessible route for individuals with disabilities with a slope greater than 1:20 but not more than a slope of 1:12 and constructed in accordance with the British Columbia Building Code; and
- (e) utilities, cisterns, storage tanks, underground parking and similar *Structures* constructed entirely beneath the surface of the ground may project into the required *Interior Side* or *Rear Setbacks* provided such underground projections are covered by sufficient soil depth to accommodate *Landscaping* and/or are *Hard Surfaces* to accommodate access needs.

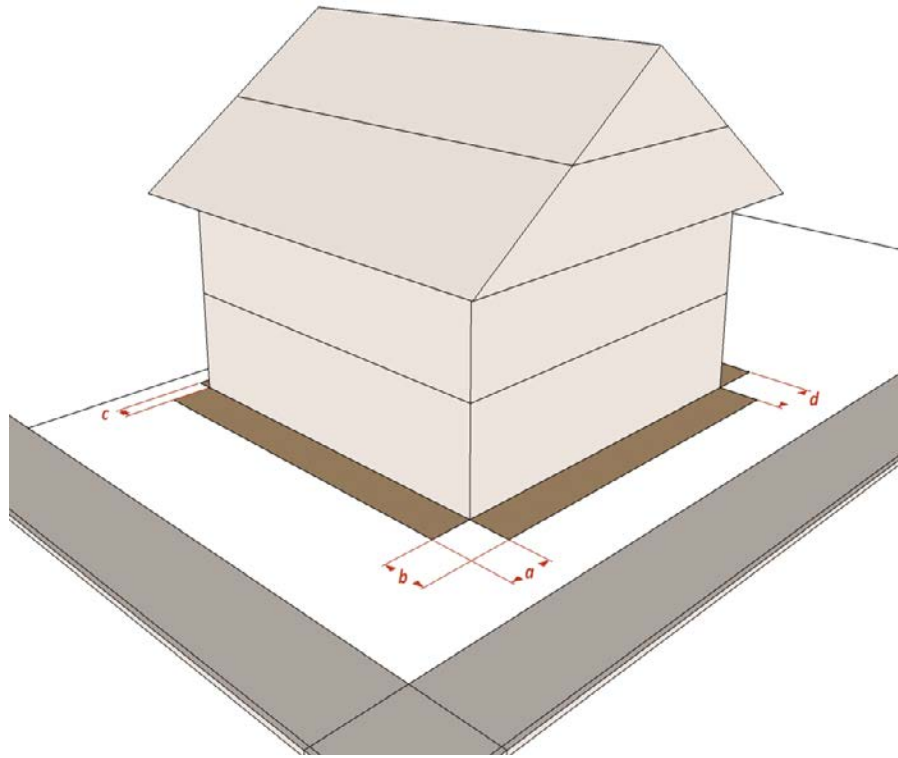

Projections into Setbacks

4.3 Height of Buildings and Structures

4.3.1 Any of the following *Structures* may exceed the maximum *Height* regulations of this Bylaw:

- (a) chimneys;
- (b) *Place of Worship* spire, belfry, steeple, dome, cupola;
- (c) communication towers, antennas or masts;
- (d) transmission towers;
- (e) utility poles;
- (f) mechanical appurtenances constituting not more than 10 percent of the total roof area of a *Building* provided that the appurtenance is screened;
- (g) flagpoles for federal, provincial or municipal flags; and
- (h) farm silos for the storage of *Agriculture Products* or wind machines intended for frost protection and not the generation of electricity.

4.4 Heritage Designated Buildings

4.4.1 Heritage designated *Buildings* shall be subject to Part 27 of the Local Government Act.

4.5 Accessory Buildings and Structures

4.5.1 Where a *Building* or *Structure* on a *Lot* shares an integrated roof *Structure* with the principal *Building* on the *Lot* and has not more than 9.5m between their closest exterior walls, it is part of the principal *Building* and is not an *Accessory Building*.

4.5.2 Shipping/cargo containers defined as a prefabricated metal container or box specifically constructed for the transport of goods by rail, ship, or transport truck are not permitted within residential zones.

4.5.3 One *Accessory Building* or *Structure* is permitted per *Lot* in all zones, except as otherwise expressly permitted in this Bylaw.

4.5.4 Accessory Buildings and Structures shall not be located in a Front or Exterior Side Yard.

4.5.5 *Accessory Buildings* and *Structures* may not contain *Bedrooms* or sleeping facilities unless they are a *Carriage House*, an *Additional Dwelling for Farm Help*, or *Temporary Farm Worker Accommodation*, except as expressly permitted in this Bylaw.

4.5.6 Unless expressly permitted elsewhere in this Bylaw:

- (a) *Accessory Buildings* and *Structures* shall be located not less than 1.5m from any *Side* and *Rear Property Line*;

Bylaw 2012-028 removed Section 4.5.6(b) in its entirety.

4.5.7 A permanent *Accessory Building* or *Structure* may be erected only after a principal *Building* has been completed on the same *Lot*, except where that *Accessory Building* or *Structure* is a *Carriage House* intended for temporary living accommodation during the construction of the principal *Building*, provided that a Building Permit has been issued for both the principal *Building* and *Carriage House*.

4.6 Vehicle Storage

4.6.1 Exterior storage or parking of more than two (2) unlicensed vehicles is prohibited in all zones other than industrial, commercial or agricultural zones described in Column 1 of Table 3.1.

4.6.2 Exterior storage or parking of a *Derelict Motor Vehicle* for more than 30 consecutive days is prohibited in all rural residential zones and urban residential zones described in Column 1 of Table 3.1.

4.7 Setbacks from Highways and Major Streets

- 4.7.1 All *Buildings* and *Structures* shall be located a minimum distance of 15.0m from any *Property Line Abutting Highway #97*.
- 4.7.2 All *Buildings* and *Structures* on *Lots Abutting a Street* designated as part of the Major Street Network Plan in the District's Official Community Plan shall have a *Building line Setback* of not less than the amount equal to the *Setback* required within the zoning of the Lot plus any amount specified as being required by the *District's Subdivision and Development Servicing Bylaw* to widen the *Street* in the future.

4.8 Swimming Pools and Artificial Bodies of Water

- 4.8.1 Swimming pools, wading pools, fish ponds and other artificial bodies of water, with a depth of more than 0.6m at any point, and an area larger than 5.0m² in area:
- (a) shall not be located in any *Front Yard* or *Exterior Side Yard*;
 - (b) shall be sited not less than 1.8m from any *Interior Side Property Line* and *Rear Property Line*; and
 - (c) shall be surrounded by a *Fence* not less than 1.2m in *Height*.
- 4.8.2 The required siting of a *Fence* around a pool shall be in compliance with Section 5.65 of this Bylaw.
- 4.8.3 The actual design specifications of a *Fence* for around a pool shall be in compliance with the *District's Building Regulation Bylaw*.

Bylaw 2014-018 amended the following 4.91 (properties exempt from building envelope) – adopted September 8th, 2014.

Bylaw 2017-028 amended Section 4.91 (Building Envelope) – adopted October 10, 2017

4.9 Building Envelope

- 4.9.1 No Residential Lot shall be created unless it contains a Building envelope with minimum area of 100 m². Properties zoned RSD1(i) Residential Single Detached Intensive Zone, are exempt from the requirement to have a 100 m² building envelope. The Building envelope must be located such that it does not encroach into the Property Line setbacks as required under the provisions of this bylaw.

5.0 Landscaping Regulations

5.1 Landscape Requirements

- 5.1.1 Screening and Landscaping shall be provided and maintained in accordance with the regulations detailed in the Landscape and Screening Schedule (Table 5.1) of this Bylaw. Where two or more standards apply, the more restrictive requirement shall prevail.
- 5.1.2 In cases where property is to be developed in phases, Landscaping need only be provided on that portion of the property to be developed in each phase. *Landscaping* shall be required in each subsequent phase as that property is redeveloped.

5.2 Landscaping and Screening

- 5.2.1 Where *Landscaping* is required by this Bylaw, every application for *Development* shall include a Landscaping plan which illustrates:
- the location or proposed footprint of all *Buildings* and *Structures* on the property;
 - positioning of any vegetation to be retained;
 - proposed plant species including sizes, numbers and locations;
 - method of irrigation;
 - the location of all *Hard Surfaced* areas such as driveways, parking areas and sidewalks;
 - existing or proposed *Finished Grades*; and
 - site lighting and *Fencing*.

- 5.2.2 Any changes to an approved *Landscape* plan must be authorized by the *District's Manager of Development Services* or the *District's Building Inspector*.

5.3 Landscape Restrictions

- 5.3.1 On a *Corner Lot* contiguous to a *Street* or lane intersection, no vegetation in any form shall be allowed at a *Height* greater than 0.9m within the *Site Triangle*.

5.4 Landscape Standards

- 5.4.1 For the purposes of this Bylaw, the following surfaces are not permeable:
- Buildings* and *Structures* with the exception of *Buildings* and *Structures* with green roofs that reduce stormwater discharge by more than 25 percent (rate and quantity);

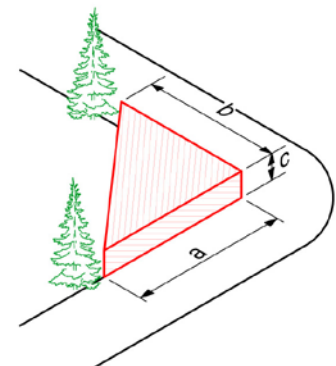

Site Triangle
($a, b > 7.0\text{m}$; $c < 0.9\text{m}$)

- (b) asphalt;
- (c) concrete; and
- (d) grouted pavers.

5.4.2 Water surfaces of *Structures* designed to retain water, including swimming pools, reflecting pools, and ornamental ponds, are considered permeable.

5.4.3 For all *Landscaped Strips*, *Landscape Screens*, or other landscaped areas required by this Bylaw, the following landscape requirements shall apply:

- (a) existing landscaped areas of healthy woody plants (trees and shrubs) shall be preserved and protected during construction unless demonstrated to the satisfaction of the *Manager of Development Services* or Building Inspector that removal is required to accommodate a *Use*, *Building* or *Structure* on the *Lot* or that the plants pose a safety hazard;
- (b) new landscape plantings, required by this Bylaw, shall consist of native xeric or water-conserving herbaceous and/or woody plant species proven to be enduring in the District of Summerland.
- (c) appropriate means of irrigation, with an emphasis on high-efficiency water reducing systems, shall be provided by the owner of the *Lot* with particular attention paid to adequate watering during the establishment period to ensure survival of the newly planted areas required by this Bylaw.

5.4.4 Notwithstanding Section 5.4.3(b), landscape screening required *Adjacent* to the *Agricultural Land Reserve* may be non-native plant material if required.

5.5 Fences & Retaining Walls

5.5.1 The *Height* of a retaining wall shall be measured from the *Finished Grade* on the lowest side of the wall.

5.5.2 A single retaining wall located within the *Front Yard*, *Rear Yard* or *Side Yard* may not exceed 1.2m in *Height*. All retaining walls located within 1.2m of each other will be collectively considered a single retaining wall for the purposes of determining *Height*.

5.5.3 Except as otherwise specifically stated in this Bylaw:

- (a) no *Fence* shall exceed 1.8m in *Height* other than wildlife fencing constructed with wire

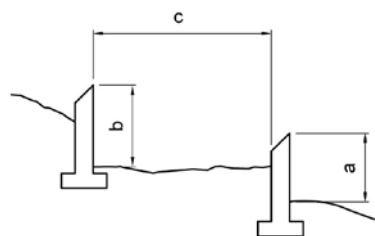

Retaining Wall
 $(a < 1.2m; b < 1.2m; c < 1.2m)$

- mesh in agricultural zones which may not exceed 2.4m in *Height*;
- (b) no *Fence* situated in the *Front Yard* or the *Exterior Side Yard* of any residential or commercial zoned *Lot* shall exceed a *Height* of 1.2m;
 - (c) no *Fence* located on a *Corner Lot* contiguous to a *Street* or lane intersection shall exceed a *Height* greater than 0.9m within the *Site Triangle*;
 - (d) no *Fence* shall be placed closer than 1.8m to the edge of a swimming pool or other artificial body of water;
 - (e) no *Fence* shall use barbed wire except in agricultural and industrial zones; and
 - (f) no *Fence* shall use razor wire.

5.5.4 *Fences* for *Outdoor Recreational Services* shall not be limited in *Height* provided such *Fences* are constructed of material that permits visibility such as wire mesh.

Table 5.1: Landscape & Screening Schedule

Bylaw 2000-465 amended the following Uses* (December 12th, 2011):

Use	Location of Landscaping & Screening Requirements	Actual Landscape & Screening Requirements
*All <i>Uses</i> with the exception of <i>Agricultural Uses</i> in all zones.	<i>Property Lines Abutting</i> lands within the <i>Agricultural Land Reserve</i> .	4.6m wide <i>Landscaped Strip</i> , plus a 1.8m high <i>Fence</i> .
All <i>Uses</i> within an industrial zone.	<i>Property Lines Abutting</i> all urban or rural residential zoned properties.	4.6m wide <i>Landscaped Strip</i> , plus a 1.8m high <i>Fence</i> .
All <i>off-Street</i> parking or outdoor storage areas within a commercial, industrial, or institutional zone.	The entire perimeter of all <i>off-Street</i> parking and/or outdoor storage areas.	3.0m wide <i>Landscaped Strip</i> . Landscape islands within the parking areas shall be provided so as to avoid having more than 20 vehicle <i>Parking Spaces</i> in a continuous row.
All <i>Uses</i> in all zones other than the production of agricultural crops.	<i>Property Lines Abutting</i> Highway #97.	4.6m wide <i>Landscaped Strip</i> .
All commercial <i>Uses</i> in the Trout Creek Development Permit Area as defined in the	<i>Property Lines Abutting</i> non-commercial zoned properties.	3.0m wide <i>Landscaped Strip</i> .

District's Official Community Plan.		
Outdoor storage facilities for more than five <i>Recreational Vehicles</i> and/or boats in all urban residential zones.	<i>Property Lines Abutting</i> a public <i>Highway</i> or neighbouring <i>Lot</i> .	1.6m wide <i>Landscaped Screen</i> or 1.8m high <i>Fence</i> .
<i>Autobody Repair Shops, Wrecking Yards</i> and outdoor storage facilities.	Surrounding outdoor storage and/or dismantling facilities.	2.4m high <i>Landscaped Screen</i> or <i>Fence</i> .

5.5.5 Notwithstanding the regulations contained in [Section 5.4.3](#), the *Agricultural Land Commission* may require greater Landscaping and screening provisions as part of any application requiring their direct approval.

6.0 Parking & Loading Regulations

6.1 Vehicle Parking and Loading Provisions

6.1.1 When any new *Development* is commenced or when any existing *Development* is enlarged, or *Use* changed, vehicle parking and loading spaces shall be provided and maintained by the property owner for parking and loading in accordance with the standards of this section.

For properties having or proposing direct access to Highway #97, additional vehicle parking and loading spaces may be required in accordance with the Ministry of Transportation and Infrastructure standards.

6.1.2 Where the calculation of the total number of vehicle parking and loading spaces results in a fractional number, the next highest whole number shall be required where such calculation results in a fraction of 0.5 or greater. In no case shall the vehicle parking and loading space provisions be less than 1 space.

6.1.3 Where a particular *Development* is not specifically identified in terms of its vehicle parking and loading requirements, the *Use* class or combination of *Use* classes most representative of the proposed *Development* shall be used to determine the on-site vehicle parking and loading requirements.

6.1.4 The minimum number of all off-*Street* vehicle parking and loading spaces shall be in accordance with the Parking & Loading Schedule (Table 6.1) of this Bylaw. Visitor *Parking Spaces* shall be clearly designated as “Visitor Parking”.

Table 6.1: Parking & Loading Schedule

Bylaw 2013-003 added the following category of use (Broadcasting Studios) – March 11th, 2013

Bylaw 2014-006 added the following category of use (Parking & Loading Schedule – Housing) to include the RPN Zone – June 23rd, 2014.

Category of Use	Required Vehicle Parking Spaces	Required Loading Spaces
<i>Agriculture, General or Intensive</i>	5 per 100m ² of <i>Gross Floor Area</i> for any packaging, processing or retail sales <i>Buildings</i> including produce stands	NIL
<i>Animal Shelters</i>	2 per 100m ² of <i>Gross Floor Area</i> , minimum of 4	NIL

<i>Amusement Establishments</i> <i>Art Galleries & Museums</i> <i>Libraries</i>	1 per 40m ² of <i>Gross Floor Area</i>	NIL
Category of Use	Required Vehicle Parking Spaces	Required Loading Spaces
<i>Auctioneering Establishments</i>	5 per 100m ² of <i>Gross Floor Area</i>	1
<i>Autobody Repair Shops</i>	2 per service bay	NIL
<i>Automobile Sales & Rentals</i> <i>Automotive & Equipment Repair Shops</i> <i>Boat Sales & Services</i> <i>Equipment Rentals</i> <i>Concrete & Asphalt Plants</i> <i>Recreational Vehicle Sales & Rentals</i>	2.5 per 100m ² of <i>Gross Floor Area</i>	1 per 1,500m ² of <i>Gross Floor Area</i>
<i>Bed & Breakfast Homes</i>	1 per 2 guestrooms	NIL
<i>Natural Resource Extraction</i> <i>Recycle Drop-Off Centres</i> <i>Storage Yards</i> <i>Wrecking Yards</i>	2 per <i>Business</i> occupant	NIL
<i>Broadcasting Studio</i>	2.5 per 100m ² of <i>Gross Floor Area</i>	NIL
<i>Business Support Services</i> <i>Personal Service Establishments</i>	2.5 per 100m ² of <i>Gross Floor Area</i>	NIL
<i>Canneries</i> <i>Commercial Storage</i> <i>Packing Houses</i> <i>Sawmills</i> <i>Bulk Fuel Depots</i> <i>Warehouse Sales Establishments</i> <i>Wineries & Cideries</i> <i>Recycling Depots</i>	0.5 per 100m ² of <i>Gross Floor Area</i>	1 per 1,500m ² of <i>Gross Floor Area</i>

<i>Child Care Centre, Minor and Major</i>	2 per 10 children, minimum of 4 spaces	NIL
<i>Place of Worship</i>	A minimum of one (1) <i>Parking Space</i> for every 10 seats or 6.0 linear meters of pew or bench, or per 20m ² of floor space used for assembly purposes, whichever is greater.	1
Category of Use	Required Vehicle Parking Spaces	Required Loading Spaces
<i>Community Recreational Services</i> Convention Centres <i>Recreational Services, Indoor</i> <i>Clubs</i> <i>Theatres</i>	2.5 per 100m ² of <i>Gross Floor Area</i> of assembly <i>Use</i> space	1
<i>Contractor Services, General or Limited</i>	2 per 100m ² of <i>Gross Floor Area</i>	NIL
<i>Convenience Stores</i> <i>Gas Bars</i> <i>Service Stations</i> Carwashes	2.5 per 100m ² of <i>Gross Floor Area</i> and 3 per service bay	NIL
<i>Eating & Drinking Establishments</i> other than within the CB1 and CB2 zones	1 per 4 seats. Unenclosed outdoor seating used on a seasonal basis is exempt from parking provided that the outdoor seating is not greater than 50 percent of the total number of approved indoor seats.	NIL
<i>Education Service, Private or Public</i>	2 per elementary or intermediate classroom; 4 per secondary classroom; 10 per college, commercial school or other post secondary classroom	NIL
<i>Financial Services</i> <i>Health Services</i>	2.5 per 100m ² of <i>Gross Floor Area</i>	NIL

<i>Fleet Services</i>	2 per 100m ² of <i>Gross Floor Area</i> ; minimum of 3	NIL
<i>Funeral Homes</i>	6.0 per 100m ² of <i>Gross Floor Area</i> for chapel, plus 2.5 per 100m ² of <i>Gross Floor Area</i>	1
Category of Use	Required Vehicle Parking Spaces	Required Loading Spaces
<i>General Industrial Uses</i>	1 per 200m ² of <i>Gross Floor Area</i>	1 per 1,500m ² of <i>Gross Floor Area</i>
Greenhouses and Plant Nurseries <i>Group Homes, Major or Minor</i>	1 per 1,500m ² of <i>Gross Floor Area</i> 1 per 2 persons licensed occupancy	NIL
Hospital	1 per 4 beds	1
<i>Hotel</i>	1 per 2 sleeping units	1
<i>Housing – Townhouse, Apartment or Dwelling Units located in the RPN Zone.</i>	1 per studio <i>Dwelling</i> unit; 1.25 per 1 <i>Bedroom Dwelling</i> ; 1.5 per 2 <i>Bedroom Dwelling</i> . 2 per 3 or more <i>Bedroom Dwelling</i> In addition, 1 designated visitor <i>Parking Space</i> per 7 <i>Dwelling</i> units.	NIL
<i>Housing - Single Detached, Duplex or Manufactured</i>	2 per <i>Dwelling</i> unit	NIL
<i>Housing - Dwelling Units located in the CB1 zone</i>	1 per <i>Dwelling</i> unit	NIL
<i>Housing - Temporary Accommodation for Farm Help</i>	1 per 3 sleeping units	NIL
<i>Housing - Secondary Suites, Employee Residential, Additional Dwelling for Farm Help</i>	1 per <i>Dwelling</i> unit	NIL
<i>Marinas</i>	1 per 2 boat spaces	NIL

<i>Motel</i>	1 per sleeping unit	NIL
<i>Offices, Research Centres and Laboratories</i>	2.5 per 100m ² of <i>Gross Floor Area</i>	1 per 1,500m ² of <i>Gross Floor Area</i>
Category of Use	Required Vehicle Parking Spaces	Required Loading Spaces
<i>Recreational Services, Outdoor</i>	1 per golf hole, 0.25 per participant, or 6 per hectare <i>Lot Area</i> , whichever is greater;	NIL
<i>Retail Stores, General</i> <i>Shopping Centres</i> Wine & Beer Stores	2.5 per 100m ² <i>Gross Floor Area</i>	1 per 1,500m ² <i>Gross Floor Area</i>
Town Centre Non-residential <i>Uses</i> (CB1 zones and Downtown Commercial in OCP)	2 per 100m ² <i>Gross Floor Area</i>	1 per 1,500m ² <i>Gross Floor Area</i>

6.2 Designated Parking Spaces

- 6.2.1 Parking areas shall designate *Parking Spaces* as parking for persons with disabilities as required by the British Columbia Building Code;
- 6.2.2 Where *Parking Spaces* are designated for the *Use* of motorcycles or scooters, such designated motorcycle/scooter *Parking Spaces* shall:
- (a) have a minimum width of 1.4m and a minimum clear length of 2.4m;
 - (b) be marked with both a vertical sign of at least 300mm wide x 450mm high and be centre mounted 1.5m to 2.5m above the surface of the parking area, and have a sign painted on the surface of the parking area, and each sign shall be the sign approved by the Transportation Association of Canada or be approved by the *District*;
 - (c) each be counted as the provision of 0.5 required vehicle *Parking Spaces*, to a maximum of 15 percent of required *Parking Spaces*.
- 6.2.3 A minimum of 10 percent of the *Parking Spaces* required according to the *Use* categories *Townhouse Housing* and *Apartment Housing* on Table 6.1, excluding visitor *Parking Spaces*, shall include receptacles to accommodate *Use* by electric vehicle charging equipment.

6.3 Shared and Off-Site Parking

6.3.1 Where a *Development Site* is occupied by multiple *Uses*, the off-*Street* vehicle *Parking Space* requirements of this Bylaw may be reduced according to the results obtained through the application of the Shared Parking Schedule (Table 6.2), by following the steps below:

- (a) Determine the off-*Street* vehicle parking requirements for each *Use* separately, based on the requirements of Table 6.1;
- (b) Apply the off-*Street* vehicle parking requirements for each *Use* obtained in the previous step to the corresponding percentages set out in each of the occupancy periods in the Shared Parking Schedule (Table 6.2);
- (c) Add the resulting reduced parking requirements by occupancy period column, for each column;
- (d) The highest occupancy period column total represents the off-*Street* shared vehicle parking requirement.

Table 6.2: Shared Parking Schedule

Classes of Use	Occupancy Period					
	Weekday			Weekend		
	8:00 - 17:00	18:00 - 24:00	24:00 - 6:00	8:00 - 17:00	18:00 - 24:00	24:00 - 6:00
Residential	60%	100%	100%	80%	100%	100%
Office / Warehouse / Industrial	100%	20%	5%	5%	5%	5%
Other Commercial	90%	80%	5%	100%	70%	5%
Hotel	70%	100%	100%	70%	100%	100%
Food primary establishment	70%	100%	10%	70%	100%	20%
Theatre	40%	80%	10%	80%	100%	10%
Entertainment	40%	100%	10%	80%	100%	50%
Conference / convention	100%	100%	5%	100%	100%	5%
Institutional	100%	20%	5%	10%	10%	5%
Religious	10%	5%	5%	100%	50%	5%

6.3.2 Where an arrangement for shared parking is or has been calculated in accordance with Section 6.3.1:

- (a) No *Business* license shall be issued to authorize a *Use* of the *Lot* unless the new *Use* continues to comply with Section 6.3.1; and

- (b) Shared off-Street vehicle *Parking Spaces* shall not be reserved for the *Use* of any specific owner, customer, or visitor of the *Uses* sharing the *Parking Spaces*.

6.4 Fee in Lieu of Parking

- 6.4.1 In the CB1 – Central Business Zone and the CT – Commercial Tourist Zone described in Column 1 of Table 3.1, the on-site vehicle *Parking Space* requirements of this Bylaw, other than for *Dwellings*, may be met by payment to the District of Summerland of \$3,000 per required off-Street *Parking Space* pursuant to Parking Reserve Fund Establishment Bylaw 96-037.
- 6.4.2 Each required *Parking Space* provided through payment in lieu of off-Street provision counts as the provision of 1.5 required off-Street *Parking Spaces*.

6.5 Vehicle Parking Space Design Standards

Bylaw 2015-009 added 6.5.1 re Garage Door setback and renumbered as required - adopted May 11th, 2015.

- 6.5.1 A garage door shall have a minimum setback of 6.0m as measured from edge of any public road right-of-way, private (strata) road, or driveway easement that provides access to the lot.
- 6.5.2 Unless otherwise permitted in Section 6 of this Bylaw, each vehicle *Parking Space* shall have a minimum width of 2.6m and a minimum clear length of 5.5m exclusive of access driveways or aisles, ramps and columns. For parallel parking, the length of the *Parking Space* shall be increased to 7.0m, except that an unobstructed end *Parking Space* shall be a minimum length of 5.5m.
- 6.5.3 All access driveways and aisles shall be a minimum of 7.2m wide for 90 degree parking, 5.5m wide for 60 degree parking, 4.0m wide for 45 degree parking and 4.0m wide for 30 degree parking. Where the parking angle is less than 90 degrees, the access driveways or aisles shall be demarcated as one-way.
- 6.5.4 Parking areas containing four or more vehicle *Parking Spaces* may designate up to 25 percent of the total vehicle *Parking Spaces* as small car parking. The small car *Parking Spaces* shall have a minimum width of 2.5m and a minimum clear length of 4.9m and be clearly designated as “Small Car Parking”.
- 6.5.5 Vehicle *Parking Spaces* may be configured in tandem for *Single Detached Housing* and *Duplex Housing*. Tandem configured *Parking Spaces* are permitted for all *Developments* in the CB1 - Central Business Zones provided access to the *Parking Spaces* is from a public lane.

- 6.5.6 All parking areas containing more than five vehicle *Parking Spaces*, shall install curbs or wheel stops to prevent vehicles from overhanging the *Property Lines*, landscaped areas or walking corridors.
- 6.5.7 Except for *Single Detached Housing* or *Duplex Housing*, the parking layout shall contain adequate provisions to ensure that manoeuvre movements into and out of *Parking Spaces* is carried out on-site.
- 6.5.8 Every vehicle parking area shall be graded in a manner so as to contain and dispose of all surface water on-site as approved by the District's Building Inspector. If on-site disposal is not possible, then all surface water must drain to a *District* storm sewer system or other approved drainage facility.
- 6.5.9 All parking areas serving Apartment Housing, Townhouse Housing, Cluster Housing, mixed-Use, or non-residential Developments shall:
- (a) be surfaced with a permanent hard surface of asphalt; concrete; permeable/porous pavement, such as open-jointed pavers, turf/gravel grids or porous concrete/ asphalt; interlocking paving stones, or similar hard surface treatment so as to provide a surface that is durable and dust-free for the purpose intended;
 - (b) be designed with a minimum of one designated pedestrian path from each *Abutting Street* to the primary entrance(s) to such *Buildings*. Pedestrian access shall be distinct from the vehicle access, visibly delineated, and designed to be safe and convenient. Specifically, internal pedestrian *Walkways* shall be distinguished from driving surfaces through the use of raised sidewalks, special pavers, bricks, or scored/stamped coloured concrete or other approved hardscape material;
 - (c) provide and maintain internal shade trees at a minimum ratio of one tree planted for every five *Parking Spaces* supplied, ensuring that no *Parking Space* is more than 30m from a tree; and
 - (d) incorporate and maintain landscaped areas within the *Parking Lot*, including islands at each end of every parking row measuring at least 3.55m by 5.5m. Parking rows may not be longer than 20 *Parking Spaces*.

6.6 Vehicle Parking Space Location and Access Standards

- 6.6.1 All access points to a parking area from a public *Highway* shall be in accordance with the Summerland Driveway Access Bylaw. Where alternative access to a lane or *Flanking Street* is available, access may be denied to a collector roadway or other public *Highway* at the discretion of the Director of Works & Utilities.
- 6.6.2 For all parking areas containing more than 20 parking stalls, no entrance to an individual *Parking Space* shall be permitted within 6.0m of the driving lane of the *Highway* used for access purposes.

- 6.6.3 For all *Uses* except for *Single Detached Housing*, *Duplex Housing*, or parking areas located within CB1- Central Business Zone, or the CB2 –Shopping Centre Zone, no off-*Street* vehicle *Parking Spaces* shall be located closer than 3.0m to the *Front Property Line*, no closer than 1.6m to the *Interior Side Property Line* or *Rear Property Line* or closer than 3.0m of any *Exterior Side Property Line*.
- 6.6.4 All required off-*Street* vehicle *Parking Spaces* shall be located on the *Development Site* requiring the vehicle *Parking Spaces*, except as provided for in [Section 6.3](#) and [Section 6.4](#) of this Bylaw.

6.7 Loading Space Standards

- 6.7.1 Each off-*Street* loading space shall not be less than 28.0m² in area, less than 3.0m in width, or have less than 4.0m in overhead clearance.
- 6.7.2 All off-*Street* loading spaces in all Commercial Zones and Site Specific CD - Comprehensive Development Zones described in column 1 of Table 3.1, unless otherwise noted, shall be surfaced with a permanent hard surface of asphalt; concrete; permeable/porous pavement, such as open-jointed pavers, turf/gravel grids or porous concrete/asphalt; interlocking paving stones, or similar hard surface treatment so as to provide a surface that is durable and dust-free for the purpose intended, and delineated with pavement markings or signage as a “Loading Zone”.
- 6.7.3 All off-*Street* loading spaces shall be graded in a manner so as to contain and dispose of all surface water on-site as approved by the District’s Building Inspector. If on-site disposal is not possible, then all surface water must drain to a *District* storm sewer system or other approved drainage facility.
- 6.7.4 All off-*Street* loading spaces shall conform to Section 5: Landscape & Screening Regulations of this Bylaw.
- 6.7.5 All required off-*Street* loading spaces shall be located on the *Development Site* requiring the loading spaces.

6.8 Loading Space Location Standards

- 6.8.1 Access to off-*Street* loading spaces shall be provided, wherever possible, internally to the *Development* or from a lane *Abutting* the *Development*. Backing up movements of vehicles into off-*Street* loading spaces from *Abutting Highways* shall be avoided.

6.9 Lighting

- 6.9.1 Any outdoor lighting shall be located and arranged in such a manner that no direct ray of light is directed at *Abutting* or *Adjacent Lots*, upwards, or interferes with the effectiveness of any traffic control device.

6.10 Bicycle Parking Space Standards

6.10.1 Bicycle parking shall be provided as indicated in the Bicycle Parking Schedule (Table 6.4):

Table 6.3: Bicycle Parking Schedule

Uses	Requirements
Apartment and/or Townhouse <i>Dwelling</i>	2 'Class A' spaces per <i>Dwelling</i> unit Minimum of 6 'Class B' spaces for any <i>Development</i> with ten or more <i>Dwelling</i> units
All other non-residential <i>Uses</i>	1 'Class A' space per 500m ² <i>Gross Floor Area</i> Minimum of 6 'Class B' spaces for any <i>Development</i> with a <i>Gross Floor Area</i> of 1,000m ² or greater

6.10.2 Bicycle parking facilities shall meet the following requirements:

- (a) All bicycle parking shall include a rack or *Structure* securely anchored to the ground which shall support the bicycle frame above the centre of gravity and shall enable the bicycle frame and front wheel to be locked to the rack with a U-style bicycle lock.
- (b) *Class A Bicycle Parking* shall be provided inside a secure room or enclosure accessible only with a separate lock and key or programmed entry system and available only to users whose bicycles are stored in the room or enclosure.
- (c) *Class B Bicycle Parking*, space, racks or *Structures* shall be provided in a convenient, well-lit location that provides visual surveillance by occupants of the *Building* the racks are intended to serve.

6.10.3 The owner or occupier of land in commercial zones for which 'Class B' Bicycle Parking Spaces are required, rather than provide the required spaces on site or off site, may contribute to the District a sum of \$200 per required bicycle space.

7.0 Specific Use Regulations

7.1 Application

7.1.1 The specific *Use* regulations shall apply to all *Development* in the District of Summerland. Where these regulations may be in conflict with any specific regulations of an individual zone or [Section 4](#) of this Bylaw, the special *Use* regulations shall take precedence.

7.2 Bed & Breakfast Homes

7.2.1 *Bed & Breakfast Homes*, where permitted in this Bylaw as an *Accessory Use*, shall comply with the following regulations:

- (a) the *Bed & Breakfast Home* shall be operated by the live-in resident of the *Single Detached Housing*;
- (b) the principal residential character or external appearance of the *Dwelling* must not be altered;
- (c) all guestrooms (*Bedrooms*) must be attached to or be part of the *Single Detached Housing*;
- (d) guestrooms (*Bedrooms*) are restricted to a maximum of four accommodating a maximum of eight guests;
- (e) the minimum size of guestrooms (*Bedrooms*) exclusive of closets, shall be 10.0m² with the minimum width and length not being less than 2.4m;
- (f) no guestrooms (*Bedrooms*) shall include a *Kitchen*;

7.2.2 Parking for *Bed & Breakfast Homes* shall be in conformance with [Section 6: Parking & Loading Regulations](#) of this Bylaw.

7.3 Secondary Suites

Bylaw 2017-032 replaced section 7.3.1 - adopted November 27, 2017

7.3.1 *Secondary Suites*, where permitted in this Bylaw as an *Accessory Use*, shall comply with the following regulations:

- (a) *Secondary Suites* shall form a single real estate entity with the principal single-unit *Dwelling*;
- (b) *Secondary Suites* shall be limited to one such Use within a principal *Dwelling* to a maximum of 90.0m² or 40 percent of the *Gross Floor Area* of the *Dwelling*, whichever is less;
- (c) *Secondary Suites* are not permitted on a *Lot* where a *Carriage House* is located.

7.3.2 Parking for *Secondary Suites* shall be in conformance with [Section 6: Parking & Loading Regulations](#) of this Bylaw.

7.4 Carriage Houses

Bylaw 2016-005 amended subsection 7.4.1(c) - Adopted April 11, 2016

Bylaw 2017-032 replaced section 7.4.1 - adopted November 27, 2017

7.4.1 *Carriage Houses*, where permitted in this Bylaw as an *Accessory Use*, shall comply with the following regulations:

- (a) *Carriage Houses* are not permitted on a *Lot* where a *Secondary Suite* is located;
- (b) the maximum *Gross Floor Area* of a *Carriage House* is no more than 90.0m²;
- (c) where a *Carriage House* is sited closer to a *Rear Property Line* than the required *Setback* for the *Principal Use*, any windows facing the rear or side *Interior Property Lines* must have a sill *Height* no lower than 1.5m above the finished floor elevation.

7.5 Dock & Boat Lift Regulations

Bylaw 2012-017 amended the following - (July 23rd, 2012):

Bylaw 2016-028 amended the following - (October 24, 2016):

7.5.1 Wharfage facilities consisting of docks and boat lifts shall be permitted as an *Accessory Use* upon obtaining authorization from the Province for a License of Occupation subject to meeting the following regulations:

- (a) only one dock shall be constructed per upland *Lot*;
- (b) no dock shall extend into Okanagan Lake more than 40.0m measured from the natural boundary;
- (c) no dock shall obstruct public access along the *Foreshore*. In cases where the dock crosses the entire *Foreshore* at a *Height* greater than 0.3m, steps must be provided on both sides of the dock to permit public access over the dock;
- (d) an individual privately owned dock shall not exceed 1.5 meters in width for access ramps and 3 meters for any other portion while a common owned dock shared by two or more upland property owners shall not exceed a width of 5.0m;
- (e) for the purposes of calculating the *Side Setback* of docks, the *Property Line* of the *Lot* will be projected into the lake perpendicular to the shoreline such that the projected line is intended to equally separate the lake space between upland *Lots*;
- (f) *Setback* from the *Side Property Line*, projected onto the beach and into the

water as described in Section 7.5.1(e), shall be a minimum of 5.0 meters or 10 meters from any other dock. Docks commonly owned and shared by two or more upland property owners are not required to provide any *Setback* provided that all affected upland property owners enter into the required "License of Occupation";

- (g) "L" and "T" shaped docks shall be permitted provided the maximum width of the *Structure* does not exceed one half the width of *Frontage* of the upland *Lot* or 9.0m, whichever is least;
- (h) siting of the docks shall be undertaken in a manner that is consistent with the orientation of neighbouring docks and avoids impacts on access to existing docks and *Adjacent* properties;
- (i) dock *Structures* shall be designed to either float or be supported by wooden or steel piles. All construction shall meet the requirements of the BC Building Code. Solid core docks will not be permitted;
- (j) all boat lifts shall be attached to or be immediately *Adjacent* to any dock *Structure*;
- (k) no roof or overhead covering shall be constructed over a boat lift or dock;
- (l) only 1 mooring buoy is permitted per 10m of the upland property line that fronts the lake, to a maximum of 3 mooring buoys per property; and
- (m) temporary moorage is defined as no longer than 72 hours of continuous moorage without a minimum of 24 hours between periods of temporary moorage.

7.5.2 Non-moorage *Uses* such as beach houses, boat houses, storage sheds, *Patios*, sundecks, hot tubs, gazebos, landscape features or *Fencing* shall not be permitted beyond the *Natural Boundary* of the upland property boundary as defined by legal survey which includes placement on the dock itself.

7.6 Home Occupations

7.6.1 *Home Occupations* within the *District* shall be divided into the following categories:

- (a) *Home Occupation* - Type 1;
- (b) *Home Occupation* - Type 2; and
- (c) *Home Occupation* - Type 3.

7.6.2 All *Home Occupation* categories, where permitted in this Bylaw as an *Accessory Use*, shall comply with the following regulations:

- (a) the *Home Occupation* shall not change the principal character or external appearance of the *Dwelling* or its *Accessory Buildings* (where permitted);
- (b) the *Home Occupation* shall have no external indication that the *Dwelling* or

its *Accessory Buildings* (where permitted) are used for a purpose other than its *Principal Use*, except for signage which is regulated under the *District's Signage Bylaw 2000-451*;

- (c) the *Home Occupation* shall have no external storage or display of materials, equipment, or finished products;
- (d) the *Home Occupation* shall not create, at anytime, a nuisance from noise, vibration, smoke, dust, odour, heat, glare, electrical or radio disturbance;
- (e) the *Home Occupation* shall not generate vehicle traffic or parking needs in excess of that permitted for and customary to the *Principal Use* of the property;
- (f) all parking for the *Home Occupation* must be provided within the site on which the *Home Occupation* is located; and
- (g) all *Home Occupations* must be licensed in accordance with the *District's Business Licensing Bylaw*.

7.6.3 Home Occupation - Type 1

- (a) In addition to the regulations outlined in Section 7.6.2 of this Bylaw, *Home Occupations -Type 1* must comply with the following:
 - (i) the *Home Occupation - Type 1* shall be conducted within the interior of the *Dwelling* and be confined to the *Use* of a phone and the keeping of records. The *Use of Accessory Buildings* for any portion of the *Business* is prohibited;
 - (ii) only residents of the *Dwelling* shall be engaged in the *Home Occupation - Type 1*;
 - (iii) the *Home Occupation - Type 1* shall not generate any clients to the *Dwelling*;
 - (iv) the *Home Occupation - Type 1* is restricted to no more than 25 percent of the floor area of the *Dwelling* up to a maximum area of 20.0m²;
 - (v) the *Home Occupation - Type 1* shall not include any goods displayed, stored or sold from the *Dwelling*;
 - (vi) the *Home Occupation - Type 1* shall not include a commercial vehicle larger than 5,600 kg gross vehicle weight parked on or about the site where the *Business* is licensed to operate; and
 - (vii) the signage for *Home Occupation – Type 1* shall be in conformance with the *District of Summerland Signage Bylaw 2000-451*.

7.6.4 Home Occupation - Type 2

- (a) In addition to the regulations outlined in [Section 7.6.2](#) of this Bylaw, *Home*

Occupations - Type 2 must comply with the following:

- (i) the *Home Occupation* - Type 2 shall be conducted within the interior of the *Dwelling* and/or one *Accessory Building*;
- (ii) only one person other than residents of the *Dwelling* shall be engaged in the *Home Occupation* - Type 2;
- (iii) the *Home Occupation* - Type 2 is restricted to no more than 25 percent of the floor area of the *Dwelling* or *Accessory Building* up to a maximum combined area of 50.0m²;
- (iv) a *Home Occupation* - Type 2 shall not include any retail sales from the property other than those goods constituting the finished product of the *Business*. Meat cutting and wrapping operations shall be restricted to properties having a minimum *Lot Area* of 0.40 hectares;
- (v) a *Home Occupation* - Type 2 shall not include a commercial vehicle larger than 5,600 kg gross vehicle weight parked on or about the site where the *Business* is licensed to operate;
- (vi) the *Home Occupation* - Type 2 shall not generate more than two clients at any given time to the site where the *Business* is licensed to operate; and
- (vii) the signage for *Home Occupation* - Type 2 shall be in conformance with the District of Summerland Signage Bylaw 2000-451.

7.6.5 Home Occupation - Type 3

- (a) In addition to the regulations outlined in [Section 7.6.2](#) of this Bylaw, *Home Occupations* - type 3 must comply with the following:
 - (i) the *Home Occupation* - Type 3 shall be conducted within the interior of the *Dwelling* and/or one *Accessory Building* on a *Lot* having a minimum *Lot* size of 0.8 ha;
 - (ii) no more than two persons other than the residents of the principal *Dwelling* shall be engaged in the *Home Occupation* - Type 3;
 - (iii) the *Home Occupation* - Type 3 is restricted to a maximum floor area of the *Dwelling* and/or the *Accessory Building* of 100m²;
 - (iv) a *Home Occupation* - Type 3 shall not include any retail sales from the property other than those goods constituting the finished product of the *Business*;
 - (v) the *Home Occupation* - Type 3 shall not affect the *Use* of the land for agricultural purposes for properties located in the *Agricultural Land Reserve*; and

- (vi) the signage for *Home Occupation* – Type 3 shall be in accordance with the District of Summerland Signage Bylaw 2000-451.

7.7 Child Care Centres, Minor and Major

7.7.1 *Child Care Centres*, where permitted in this Bylaw, shall comply with the following regulations:

- (a) the centre has successfully completed a fire and safety inspection relative to the requirements of the BC Building Code;
- (b) the centre meets the regulations of the Ministry of Health for on-site waste water disposal in cases where connection to the community's sanitary sewer is not possible;
- (c) the centre is licensed in accordance with the *District's* Business License Bylaw as well as with the applicable provincial ministry; and
- (d) the centre can provide an on-site drop off area which would avoid the *Use* of the *Abutting Highway* right-of-way for picking up and dropping off children.

7.7.2 Parking for *Child Care Centres* shall be in conformance with [Section 6: Parking & Loading Regulations](#) of this Bylaw.

7.8 Group Homes, Minor

7.8.1 *Group Homes, Minor*, where permitted in this Bylaw as an *Accessory Use*, shall comply with the following regulations:

- (a) the *Group Home, Minor* shall be operated by a live-in manager of the sponsoring agency or live-in owner of the *Single Detached Dwelling*;
- (b) the principal residential character or external appearance of the *Dwelling* must not be altered;
- (c) the *Group Home - Minor* is not operated in conjunction with an approved *Bed & Breakfast Home*, a *Secondary Suite*, a *Carriage House* or an approved *Child Care Centre*;
- (d) the *Group Home - Minor* meets the regulations of the Ministry of Health for on-site waste water disposal in cases where connection to the community's sanitary sewer is not possible; and
- (e) the *Group Home - Minor* is licensed in accordance with the *District's* Business License Bylaw as well as with the applicable provincial ministry.

7.8.2 Parking for *Group Homes - Minor* shall be in conformance with [Section 6: Parking & Loading Regulations](#) of this Bylaw.

7.9 Service Stations and Gas Bars

7.9.1 All *Service Stations*, *Gas Bars* and fuel distribution facilities shall meet the following requirements:

- (a) the placement and maintenance of fuel storage tanks exceeding 10 litres is permitted only within industrial zones or within a zone which permits *Service Stations* or *Gas Bars* as a permitted *Use*, except where the tank is used strictly for on-site purposes;
- (b) all fuel distribution pumps or devices shall be located a minimum of 3.5m from any *Property Line*;
- (c) *Canopies* over gasoline pumps and pump islands shall be located a minimum of 2.0m from any *Property Line*;
- (d) outside merchandise display booths shall be located a minimum of 5.0m from any *Property Line Abutting a Highway*;
- (e) all servicing equipment, other than that normally situated on a pump island, shall be entirely enclosed within a *Building*;
- (f) all tires, automobile accessories and related goods shall be located on pump islands or contained within a booth, rack or stand;
- (g) a maximum of two outdoor merchandise display booths, racks or stands shall be permitted per *Lot* or *Development Site*;
- (h) outdoor storage of machinery, equipment or vehicles in a state of disrepair shall not be permitted; and
- (i) all areas utilized by automobiles for the purpose of gaining access to and from gasoline pumps or service bays of the principal *Structure* shall be *Hard Surfaced*.

Bylaw 2014-029 amended the following, by changing the heading to read (November 10th, 2014):

7.10 Temporary Use Permit Areas

7.10.1 All lands zoned A1-Agricultural Small Acreage or A2-Agricultural Large Acreage currently located in the *Agricultural Land Reserve* are designated as a Temporary Use Permit Area.

Bylaw 2014-029 added the following as Section 7.10.2 and renumbered all subsequent sections.

7.10.2 All lands zoned CM – Heavy Commercial are designated as a Temporary Use Permit Area.

Bylaw 2015-031 added the following as Section 7.10.3 and renumbered all subsequent sections.

7.10.3 The lands described as Lot 1, DL 455 and 5085, ODYD, Plan 5896, located at 13415 Lakeshore Drive, is designated as a Temporary Use Permit Area.

7.10.4 A Temporary Use Permit within the Temporary Use Permit Area for an agri-tourism accommodation or a *Campground* will be considered for approval by Council based on the following, including but not limited to:

- (a) a maximum of 10 campsites will be permitted including any approved Bed & Breakfast guestrooms;
- (b) all or part of the Lot must be classified as farm under the Assessment Act;
- (c) the total developed area for such a *Use* including *Accessory Buildings, Landscaping* and access, (driveway and parking) must be less than five percent of the total *Lot Area*;
- (d) the *Lot* containing the agri-tourism accommodation or a *Campground* is at least 2.0ha in size
- (e) the proposed agri-tourism accommodation or a *Campground* has the following *Setbacks*:
 - (i) *Front Setback* – 15.0m
 - (ii) *Side Yard and Rear Setback* – 30.0m;
- (f) the proposed campsites are no closer than 60.0m to any neighbouring residential *Dwellings*.
- (g) campfires are to be limited to a single, centrally located campfire pit and must be requested as part of the Temporary Use Permit.
- (h) methods to control potential late night noise and disturbances such as around a proposed campfire facility must be included as part of the applicant's Temporary Use Permit request.
- (i) washroom facilities approved by the Provincial Health Authority are required or the permit will limit the temporary *Use* to *Recreational Vehicles* with self-contained domestic water and septic disposal systems.
- (j) no *Recreational Vehicle* can be located on a campsite any longer than 30 consecutive days.

7.10.5 The *District* may require a security bond and impose performance measures as a condition for the issuance of a Temporary Use Permit.

7.10.6 Upon expiration of a Temporary Use Permit, the *Uses* allowed on the *Lot* shall revert to those outlined under the specific zoning category placed on that *Lot*. The applicant may, prior to the expiration of the Temporary Use Permit, apply for a one time only extension of three years, approval of which is at the discretion of Council.

7.11 Renewable Energy Systems and Infrastructure

7.11.1 There must be an active *Principal Use* on a *Lot* in order to locate a private renewable energy or co-generation device on the *Lot*.

7.11.2 The production of the renewable or co-generation energy as well as any device used to produce the energy must comply with all other Municipal, Provincial and Federal Bylaws, Statutes and Regulations including but not limited to a Building Permit and BC Building Code Regulations.

7.11.3 Solar Energy Devices:

- (a) In residential and commercial zones, solar energy devices shall be permitted provided that the solar energy device shall:
 - (i) be attached to a principal or *Accessory Building*; and
 - (ii) not extend beyond the outermost edge of the roof.
- (b) In agricultural, industrial and institutional zones, solar energy devices shall be permitted provided that:
 - (i) the device is located on or within the either principal or *Accessory Building* in which case the device shall not extend beyond the outermost edge of the roof; or
 - (ii) as a standalone *Structure* subject to the zoning requirements for the principal *Building* on the *Lot* where the device is located.

7.11.4 Geothermal Energy Devices

- (a) In all zones, all above-ground parts of the geothermal energy devices are subject to the zoning requirements for an *Accessory Building* or *Structure* on a *Lot*;
- (b) In all zones, the underground geothermal energy components shall be a minimum 3.0m away from all *Property Lines*; and
- (c) Geothermal energy systems requiring access to Okanagan Lake or any other *Watercourses* must obtain authorization from the Province.

7.11.5 Wind Energy Devices

- (a) In all zones, all above-ground parts of the small scale wind energy devices which generate up to 10kw shall be subject to the zoning requirements for an *Accessory Building* or *Structure* on a *Lot*, subject to the following regulations:
 - (i) only one wind energy device is permitted on each *Lot*;
 - (ii) the *Lot* on which a wind energy device is located shall be 2ha or

- greater in size;
 - (iii) maximum *Height* of a wind energy device (including the blades) shall be 10.5m as measured from the *Finished Grade*; and
 - (iv) a wind energy device tower shall have a minimum separation from any *Dwelling* unit on an *Adjacent Lot* that is a distance equal to 125 percent of the total *Height* of the device (including support *Structure* and blades).
- (b) For industrial, institutional, agricultural and commercial zones that are not *Adjacent* to residential zones, wind energy devices which generate up to 20kw shall be permitted as an *Accessory Use*, subject to the following requirements:
- (i) only one wind energy device is permitted on each *Lot*;
 - (ii) the *Lot* on which a wind energy device is located shall be 0.2ha or greater in size;
 - (iii) maximum *Height* of a wind energy device (including the blades) shall be 21.0m as measured from the ground; and
 - (iv) a wind energy device tower shall have a minimum separation from any *Dwelling* unit on an *Adjacent Lot* that is a distance equal to 125 percent of the total *Height* of the device (including support *Structure* and blades).
- (c) For industrial, institutional and commercial *Lots Abutting* residential zones, wind energy devices may be installed subject to the requirements and conditions noted above in Section 7.11.5(a).

8.0 Agricultural Zones

8.1 A1 Agricultural Small Acreage Zone

A1

8.1.1 Purpose

To provide a zone to accommodate existing small *Lot Agricultural Uses*. Lands must be designated as Agriculture under the *District's* Official Community Plan.

8.1.2 Principal Uses

The following *Uses* and no other *Uses* shall be the permitted *Principal Uses* in this zone subject to all applicable regulations of this Bylaw:

- (a) *Agriculture, General;*
- (b) *Agriculture, Intensive;*
- (c) *Greenhouses and plant nurseries;*
- (d) *Manufactured Housing - Type 1 or 2; and*
- (e) *Single Detached Housing.*

8.1.3 Accessory Uses

The following *Uses* and no other *Uses* shall be the permitted *Accessory Uses* in this zone subject to all applicable regulations of this Bylaw:

- (a) *Accessory Buildings and Structures;*

Bylaw 2000-459 added the following definition (b) - (November 14, 2011):

- (b) *Animal Shelter, Major on Lots having a minimum Lot Area of 2.0ha;*
- (c) *Bed & Breakfast home;*

Bylaw 2015-024 amended the following (d) (November 9, 2015)

- (d) *Brewing & Distilling;*

Bylaw 206-031 added the following definition (e) – (September 12, 2016)

- (e) *Child Care Centre, Minor;*
- (f) *Commercial Kennel on Lots having a minimum Lot Area of 4.0ha;*
- (g) *Dwelling for farm help;*
- (h) *Home Occupation - Type 1,2 or 3;*

Bylaw 2017-032 added (i) Secondary Suite - adopted November 27, 2017

- (i) *Secondary Suite;*
- (j) *stable;*
- (k) *Temporary Farm Worker Accommodation;*

- (l) *Winery & Cidery*; and
- (m) automotive and boat repair shop as a Type 3 *Home Occupation Use* on property at 19555 Matsu Drive (Lot 7, DL 2194, ODYD, Plan 267 Except Plans 34018, 41387, H577 and B3577) subject to the following limitations:
 - (i) for the purposes of this *Use* only, located in an *Accessory Building*;
 - (ii) for the purposes of this *Use* only, the *Home Occupation* portion of the *Accessory Building* is in addition to the area permitted under [Section 8.1.9\(b\)](#);
 - (iii) limited to no more than one person other than the residents of the principal *Dwelling* being engaged in the *Home Occupation*; and
 - (iv) a landscape hedge is to be maintained.

Bylaw 2014-010 added the following definition (k) - (July 28th, 2014):

- (n) *Campground*, as a site specific accessory use on Lot A, DL 472, ODYD, Plan 3128, located at 11208 Sanborn Street subject to the following regulations:
 - i) Compliance with the Agricultural Land Reserve Use, Subdivision and Procedure Regulation.
 - ii) Compliance with Sections 63 and 64 of the Provincial Integrated Pest Management Regulation with respect to posting notification to spray and ensuring the campground is unoccupied in accordance with these sections due to spraying.
 - iii) Seasonal operation between April 1st and October 30th of any given year.
 - iv) Daily quiet time from 10:00pm to 6:00am.
 - v) Campsites setbacks:
 - a. Front yard setback – 15.0 meters
 - b. Side yard and rear yard setback – 30.0 meters
 - c. Campsites are no closer than 60.0 meters to any neighbouring residential dwellings.
 - vi) Campfires are only permitted in one centrally located campfire pit as approved by the District of Summerland’s Fire Department.
 - vii) Camping units are limited to recreational vehicles with self-contained water and septic disposal systems unless the campground has washroom facilities meeting the minimum requirements of the Provincial Health Authority.
 - viii) No camping unit can be located on a campsite any longer than 30 consecutive days.

8.1.4 Subdivision Regulations

Bylaw 2012-017 amended the following definition (c) - (July 23rd, 2012):

- (a) Minimum *Lot Area* 2.0ha
- (b) Minimum *Lot Width* 60.0m
- (c) Notwithstanding 8.1.4 (a) and (b), where the *District Council* has supported and the *Agricultural Land Commission* has granted an application for subdivision to accommodate:
 - (i) a homesite severance in accordance with *Agricultural Land Commission* policy #025/78 as amended from time to time; or
 - (ii) the consolidation of legal *Lots* which does not result in an increase in the total number of *Lots*;
 - (iii) the *Lot Area* shall in no case be less than 1,400m²; and
 - (iv) the Minimum *Lot Width* shall in no case be less than 20.0m.

8.1.5 *Development* Regulations (A1)

Bylaw 2000-464 amended the following definition (g) - (December 12, 2011):

Bylaw 2012-017 amended the following definition (e) - (July 23rd, 2012):

Bylaw 2015-009 amended the following by adding 'lot coverage regulations' (A1 and A2 zones) – adopted May 11th, 2015.

- (a) Maximum *Farm Home Plate* 905m²
- (b) Maximum *Farm Home Plate* with a *Temporary* and/or *Additional Dwelling for Farm Help* 1,500m²
- (c) Maximum coverage for all *Buildings* and *Structures* within the *Farm Home Plate* 35 percent of the *Farm Home Plate*
- (d) Maximum coverage for all *Buildings* and *Structures* outside the *Farm Home Plate* 10 percent of the *Lot*
- (e) Notwithstanding Section 8.1.5(d) Maximum coverage for all *Buildings* and *Structures* where a *Lot* is 2.0ha or greater in size on which the *Principal Use* is greenhouses or plant nurseries 65 percent of the *Lot*
- (f) Maximum *Height* for principal *Buildings* and *Structures* within a *Farm Home Plate* The lesser of 9.5m or 2 *Storeys*

- | | | |
|-----|--|--------------------------------|
| (g) | Maximum <i>Height</i> for <i>Accessory Buildings</i> and <i>Structures</i> within a <i>Farm Home Plate</i> | The lesser of 11m or 2 Storeys |
| (h) | Maximum <i>Height</i> for agricultural <i>Buildings</i> and <i>Structures</i> identified in 8.1.6(c) | 12.0m |

8.1.6 Siting Regulations

Bylaw 2012-025 amended the following definition (a) and (b) - (November 26th, 2012):

- | | | |
|-------|--|------|
| (a) | Principal and <i>Accessory Buildings</i> and <i>Structures</i> within a <i>Farm Home Plate</i> and crop, machinery and/or chemical storage <i>Buildings</i> outside a <i>Farm Home Plate</i> . | |
| (i) | Minimum <i>Front Yard Setback</i> | 7.0m |
| (ii) | Minimum <i>Rear Yard Setback</i> | 7.0m |
| (iii) | Minimum <i>Side Yard Setback (Interior)</i> | 4.0m |
| (iv) | Minimum <i>Side Yard Setback (Exterior)</i> | 4.5m |

Bylaw 2015-024 amended the following (b) (November 9, 2015)

- | | | |
|-------|---|-------|
| (b) | Greenhouses; <i>Wineries</i> ; <i>Cideries</i> ; <i>Brewing & Distilling</i> ; <i>Buildings</i> and <i>Structures</i> housing animals, livestock or poultry; livestock feeding stations; mushroom growing facilities; and all other <i>Structures</i> : | |
| (i) | Minimum <i>Front Yard Setback</i> | 15.0m |
| (ii) | Minimum <i>Rear Yard Setback</i> | 30.0m |
| (iii) | Minimum <i>Side Yard Setback (Interior)</i> | 30.0m |
| (iv) | Minimum <i>Side Yard Setback (Exterior)</i> | 15.0m |

8.1.7 Additional Dwelling for Farm Help regulations (A1):

Bylaw 2015-009 amended Sections 8.1.7(b)(iv) and 8.2.7(b)(iv) Additional Dwelling for Farm Help regulations – adopted May 11th, 2015.

- | | | |
|-----|--|--|
| (a) | Where the <i>Lot Area</i> equals or exceeds 2.0ha of arable land, and the intensity of farming requires permanent farm help, one <i>Additional Dwelling for Farm Help</i> per <i>Lot</i> may be constructed, sited within the <i>Farm Home Plate</i> . | |
| (b) | <i>Additional Dwelling for Farm Help</i> shall: | |
| (i) | be limited to a <i>Lot</i> classified as farmland under the <u>Assessment Act</u> ; | |

- (ii) be limited to one *Dwelling* per *Lot*;
- (iii) not be permitted unless there is registered in the Land Title Office a restrictive covenant in respect of any *Additional Dwelling for Farm Help* restricting such *Dwelling to Use* as an *Additional Dwelling for Farm Help*;
- (iv) conform to the following:
 - a. may not contain more than three *Bedrooms*;
 - b. may not exceed 110m² in *Gross Floor Area*;
 - c. may not exceed the lesser of 4.5m or one *Storey* in *Height*; and
 - d. may not have a *Basement*.

8.1.8 Temporary Farm Worker Accommodation regulations

- (a) Where the *Lot Area* equals or exceeds 2.0ha of arable land, and the intensity of farming requires *Temporary Farm Worker Accommodation*, one *Temporary Farm Worker Accommodation* may be constructed, sited within the *Farm Home Plate*.
- (b) *Temporary Farm Worker Accommodation* shall:
 - (i) be limited to a *Lot* classified as farmland under the Assessment Act;
 - (ii) not be permitted unless there is registered in the Land Title Office a restrictive covenant in respect of any *Temporary Farm Worker Accommodation* restricting such *Dwelling to Use* as *Temporary Farm Worker Accommodation*;
 - (iii) conform to the following:
 - a. may not exceed 186m² in total floor space;
 - b. no individual room containing sleeping facilities may exceed 12.0m²; and
 - c. may not have a *Basement*.

8.1.9 Other Regulations

- (a) Only two (2) *Dwellings* shall be permitted per *Lot*.
- (b) Only two (2) *Accessory Buildings* or *Structures* related to residential usage shall be permitted per *Lot* with a maximum combined *Gross Floor Area* of 100m².
- (c) Parking and loading areas and access driveways for greenhouses and plant nurseries located within 30.0m of a residential *Property Line* shall provide a 6.0m wide landscape buffer along that affected *Property Line*.

- (d) *Commercial Kennels*, including any outdoor runs or exercise areas shall be located a minimum of 300m from any *Property Line*. A 6.0m wide *Buffer Strip* including a 1.8m high opaque *Fence* shall be provided around the perimeter of any outdoor runs or exercise area.

Bylaw 2000-459 added the following definition (e) - (November 14, 2011):

- (e) *Animal Shelter*, including any outdoor runs or exercise areas shall be located a minimum of 30m from any property line.
- (f) In addition to the regulations listed above, other regulations may apply. These include [Section 4: General Regulations](#), [Section 5: Landscaping and Screening Regulations](#), [Section 6: Parking and Loading Regulations](#), and [Section 7: Specific Use Regulations](#).

8.2 A2 Agricultural Large Acreage Zone

A2

8.2.1 Purpose

To provide a zone to accommodate Agricultural *Uses*. Lands must be designated as Agriculture under the *District's* Official Community Plan.

8.2.2 Principal Uses

The following *Uses* and no other *Uses* shall be the permitted *Principal Uses* in this zone subject to all applicable regulations of this Bylaw:

- (a) *Agriculture, General;*
- (b) *Agriculture, Intensive;*
- (c) greenhouses and plant nurseries;
- (d) *Manufactured Housing - Type 1 or 2; and*
- (e) *Single Detached Housing.*

Bylaw 2012-017 amended the following (July 23rd, 2012):

8.2.3 Accessory Uses

The following *Uses* and no other *Uses* shall be the permitted *Accessory Uses* in this zone subject to all applicable regulations of this Bylaw.:

- (a) *Accessory Buildings and Structures;*

Bylaw 2000-459 added the following definition (b) - (November 14, 2011):

- (b) *Animal Shelter, Major* on Lots having a minimum Lot Area of 2.0ha;
- (c) *Bed & Breakfast home;*

Bylaw 2015-024 added the following (d) - (November 9, 2015)

- (d) *Brewing & Distilling;*

Bylaw 2016-031 added the following (e) – (September 12, 2016)

- (e) *Child Care Centre, Minor;*
- (f) *Commercial Kennel* on Lots having a minimum *Lot Area* of 4.0 hectares;
- (g) *Dwelling* for farm help;
- (h) *Home occupations - type 1, 2 or 3;*
- (i) *Stable*
- (j) *Temporary Farm Worker Accommodation;* and
- (k) *Winery & Cidery.*

8.2.4 Subdivision Regulations

Bylaw 2012-017 amended the following - (July 23rd, 2012):

- | | | |
|-------|--|-------|
| (a) | Minimum <i>Lot Area</i> | 8.0ha |
| (b) | Minimum <i>Lot Width</i> | 60.m |
| (c) | Notwithstanding Section 8.2.4(a), where the <i>District Council</i> has supported and the <i>Agricultural Land Commission</i> has granted an application for subdivision to accommodate: | |
| (i) | a home-site severance in accordance with <i>Agricultural Land Commission</i> policy #025/78 as amended from time to time; or | |
| (ii) | the consolidation of legal <i>Lots</i> which does not result in an increase in the total number of <i>Lots</i> ; | |
| (iii) | a subdivision to acquire road right-of-way where and existing travelled road exists and no more than one additional <i>Lot</i> is created; | |
| (iv) | the <i>Lot Area</i> shall in no case be less than 1,400m ² ; and | |
| (v) | the Minimum <i>Lot Width</i> shall in no case be less than 20.0m. | |

8.2.5 *Development Regulations (A2)*

Bylaw 2000-464 amended the following definition (f) - (December 12, 2011):

Bylaw 2012-017 added the following definition as (e) - (July 23rd, 2012):

Bylaw 2015-009 amended the following by adding 'lot coverage regulations' (A1 and A2 zones) – adopted May 11th, 2015.

- | | | |
|-----|---|--|
| (a) | Maximum <i>Farm Home Plate</i> | 1,200m ² |
| (b) | Maximum <i>Farm Home Plate</i> with a <i>Temporary Farm Workers Accommodation</i> and/or <i>Additional Dwelling for Farm Help</i> | 2,000m ² |
| (c) | Maximum <i>Lot Coverage</i> for all <i>Buildings and Structures</i> within the <i>Farm Home Plate</i> | 35 percent of the <i>Farm Home Plate</i> |
| (d) | Maximum coverage for all <i>Buildings and Structures</i> outside the <i>Farm Home Plate</i> | 10 percent of the <i>Lot</i> |
| (e) | Notwithstanding Section 8.2.5(d) Maximum <i>Lot Coverage</i> for all <i>Buildings and Structures</i> | 65 percent of |

	where the <i>Principal Use</i> is greenhouses or plant nurseries	the <i>Lot</i>
(f)	Maximum <i>Height</i> for principal <i>Buildings</i> and <i>Structures</i> within a <i>Farm Home Plate</i>	The lesser of 9.5m or 2 <i>Storeys</i>
(g)	Maximum <i>Height</i> for <i>Accessory Buildings</i> and <i>Structures</i> within a <i>Farm Home Plate</i>	The lesser of 11m or 2 <i>Storeys</i>
(h)	Maximum <i>Height</i> for <i>Agricultural Buildings</i> and <i>Structures</i> identified in Section 8.1.6(c)	12.0m

8.2.6 Siting Regulations

Bylaw 2012-025 amended the following definition (a) and (b) - (November 26th, 2012):

- (a) Principal and *Accessory Buildings* and *Structures* within a *Farm Home Plate* and crop, machinery and/or chemical storage *Buildings* outside a *Farm Home Plate*.
- | | | |
|-------|---|------|
| (i) | Minimum <i>Front Yard Setback</i> | 7.0m |
| (ii) | Minimum <i>Rear Yard Setback</i> | 7.0m |
| (iii) | Minimum <i>Side Yard Setback (Interior)</i> | 4.0m |
| (iv) | Minimum <i>Side Yard Setback (Exterior)</i> | 4.5m |

Bylaw 2015-024 amended the following (November 9, 2015)

- (b) Greenhouses; *Wineries*; *Cideries*; *Brewing & Distilling*; *Buildings* and *Structures* housing animals, livestock or poultry; livestock feeding stations; mushroom growing facilities; and all other *Structures*:
- | | | |
|-------|---|-------|
| (i) | Minimum <i>Front Yard Setback</i> | 15.0m |
| (ii) | Minimum <i>Rear Yard Setback</i> | 30.0m |
| (iii) | Minimum <i>Side Yard Setback (Interior)</i> | 30.0m |
| (iv) | Minimum <i>Side Yard Setback (Exterior)</i> | 15.0m |

8.2.7 Additional Dwelling for Farm Help regulations:

Bylaw 2015-009 amended Sections 8.1.7(b)(iv) and 8.2.7(b)(iv) Additional Dwelling for Farm Help regulations – adopted May 11th, 2015.

- (a) Where the *Lot Area* equals or exceeds 2.0ha of arable land, and the intensity of farming requires permanent farm help, one *Additional Dwelling*

for Farm Help per Lot may be constructed, sited within the *Farm Home Plate*.

- (b) *Additional Dwelling for Farm Help* shall:
 - (i) be limited to a *Lot* classified as farmland under the Assessment Act;
 - (ii) be limited to one *Dwelling per Lot*;
 - (iii) not be permitted unless there is registered in the Land Title Office a restrictive covenant in respect of any *Additional Dwelling for Farm Help* restricting such *Dwelling to Use* as an *Additional Dwelling for Farm Help*;
 - (iv) conform to the following:
 - a. may not contain more than three *Bedrooms*;
 - b. may not exceed 110m² in *Gross Floor Area*;
 - c. may not exceed the lesser of 4.5m or one *Storey* in *Height*;
 - d. may not have a *Basement*.

8.2.8 Temporary Farm Worker Accommodation regulations

- (a) Where the *Lot Area* equals or exceeds 2.0ha of arable land, and the intensity of farming requires temporary farm help, one *Temporary Farm Worker Accommodation* may be constructed, sited within the *Farm Home Plate*.
- (b) *Temporary Farm Worker Accommodation* shall:
 - (i) be limited to a *Lot* classified as farmland under the Assessment Act;
 - (ii) not be permitted unless there is registered in the Land Title Office a restrictive covenant in respect of any *Temporary Farm Worker Accommodation* restricting such *Dwelling to Use* as *Temporary Farm Worker Accommodation*;
 - (iii) conform to the following:
 - a. may not exceed 186m² in total floor space;
 - b. no individual room containing sleeping facilities may exceed 12.0m²; and
 - c. may not have a *Basement*.

8.2.9 Other Regulations

- (a) Only two (2) *Dwellings* shall be permitted per *Lot*.
- (b) Only two (2) *Accessory Buildings* or *Structures* related to residential usage shall be permitted per *Farm Home Plate* with a maximum combined *Gross Floor Area* of 100m².

- (c) Parking and loading areas and access driveways for greenhouses and plant nurseries located within 30.0m of a residential *Property Line* shall provide a 6.0m wide landscape buffer along that affected *Property Line*.
- (d) *Commercial Kennels*, including any outdoor runs or exercise areas shall be located a minimum of 300m from any *Property Line*. A 6.0m wide *Buffer Strip* including a 1.8m high opaque *Fence* shall be provided around the perimeter of any outdoor runs or exercise area.

Bylaw 2000-459 added the following definition (e) - (November 14, 2011):

- (e) *Animal Shelter*, including any outdoor runs or exercise areas shall be located a minimum of 30m from any Property line.
- (f) In addition to the regulations listed above, other regulations may apply. These include [Section 4: General Regulations](#), [Section 5: Landscaping and Screening Regulations](#), [Section 6: Parking and Loading Regulations](#), and [Section 7: Specific Use Regulations](#).

9.0 Rural Residential Zones

9.1 CR1 Country Residential Zone

CR1

9.1.1 Purpose

To provide a zone to accommodate residential *Developments* on larger *Lots* employing conventional subdivision designs in rural areas where sanitary sewer services are unavailable. Lands must be designated as Rural Residential under the *District's* Official Community Plan.

9.1.2 Principal Uses

The following *Uses* and no other *Uses* shall be the permitted *Principal Uses* in this zone subject to all applicable regulations of this Bylaw:

- (a) *Manufactured Housing – Type 1*; and
- (b) *Single Detached Housing*.

9.1.3 Accessory Uses

The following *Uses* and no other *Uses* shall be the permitted *Accessory Uses* in this zone subject to all applicable regulations of this Bylaw:

- (a) *Accessory Building and Structures*;
- (b) *Agriculture, General*, for *Lots* having a minimum *Lot Area* of 1.0ha;
- (c) *Bed & Breakfast Home*;

Bylaw 2017-032 added (d) Carriage House - adopted November 27, 2017

- (d) *Carriage House*;
- (e) *Child Care Centre, Minor*;
- (f) *Group Home, Minor*;
- (g) *Home Occupation – Type 1, 2 or 3*; and
- (h) *Secondary Suite*

Bylaw 2015-008 added the following definition (h) - (May 11th, 2015):

- (i) *Home Occupation – Type 1, 2 or 3 – to board up to 5 canines*, as a site specific accessory use on Lot B, District Lot 488, Plan 26797, located at 2705 Johnson Street.

9.1.4 Subdivision Regulations

- (a) Minimum *Lot Area* 1.0ha
- (b) Minimum *Lot Width* 45.0m

Bylaw 2015-027 added new (c) (November 23, 2015)

- (c) For Lot 1, District Lot 1178, Osoyoos Division Yale District, Plan KAP91886 (18654 Garnet Valley Road) and that Part District Lot 1178 Outlined in Red on Plan B1755, Osoyoos Division Yale District, Except Parts Outlined Red on Plans B5590, B3577 and B7646 and except Plan KAP91886 (19013 Bentley Road); to accommodate the comprehensive cluster development of single detached housing in a bare land strata format or conventional fee simple subdivision format:
- i. Minimum Lot Size 1,300 sq. m
 - ii. Minimum Lot Width 20.0m
 - iii. Minimum Lot Depth 35.0m

9.1.5 *Development Regulations*

- (a) Maximum *Lot Coverage* for lot areas up to and including 2,050m² 30 percent
- (b) Maximum *Lot Coverage* for lot areas above 2,050m² up to and including 4,000m² 20 percent
- (c) Maximum *Lot Coverage* for lot areas above 4,000m² 10 percent
- (d) Notwithstanding Section 9.1.5 (c), a *Lot* having agricultural *Buildings* or *Structures* associated with an *Accessory Use of General Agriculture* may increase the maximum *Lot Coverage* to 30 percent.
- (e) Maximum *Height* The lesser of 9.5m or 2 *Storeys*

9.1.6 *Siting Regulations*

Bylaw 2012-017 amended the following section (iii) - (July 23rd, 2012):

- (a) Principal *Buildings* and *Structures*:
 - (i) Minimum *Front Setback* 7.0m

- (ii) Minimum *Rear Setback* 7.5m
- (iii) Minimum *Side Setback (Interior)* 1.5m (see vi)
- (iv) Minimum *Side Setback (Exterior)* 4.5m
- (v) Maximum *Height* The lesser of 9.5m or 2 Storeys
- (vi) Notwithstanding Section 9.1.6(a)(iii), a *Lot* having no direct vehicular access to the *Rear Yard* shall maintain one *Side Yard Setback* of at least 3.0m.

(b) *Accessory Buildings and Structures:*

- (i) Minimum *Front Setback* 7.0m
- (ii) Minimum *Rear Setback* 1.5m
- (iii) Minimum *Side Setback (Interior)* 1.5m
- (iv) Minimum *Side Setback (Exterior)* 4.5m
- (v) Maximum *Height* The lesser of 4.5m or 1 Storey
- (vi) Notwithstanding Section 9.1.6(b)(i), (ii), (iii), and (iv), *Accessory Buildings and Structures* Housing animals shall be located no closer than 15.0m to any neighbouring residential *Dwelling* or *Abutting Property Line*.

9.1.7 Other Regulations

- (a) Only one (1) principal *Dwelling* will be permitted per *Lot*.

Bylaw 2012-028 replaced the following definition 9.1.7(b) – CR1-Country Residential Zone:

- (b) *'Accessory Buildings or Structures* will be limited to a maximum of:
 - (i) 100m² in area or 25% of the allowable lot coverage, whichever is greater, where the Lot Area is equal to or exceeds 1.0ha or,
 - (ii) 75m² or 25% of the allowable Lot Coverage, whichever is greater, where the *Lot Area* does not exceed 1.0ha.
- (c) The keeping of livestock shall be subject to the regulations of the *District's* "Animal Control Bylaw No. 93-028".
- (d) In addition to the regulations listed above, other regulations may apply. These include [Section 4: General Regulations](#), [Section 5: Landscaping and Screening Regulations](#), [Section 6: Parking and Loading Regulations](#), and [Section 7: Specific Use Regulations](#).

10.0 Urban Residential Zones

10.1 RSD1 Residential Medium Lot Zone

RSD1

10.1.1 Purpose

To provide a zone to accommodate the *Development of Single Detached Housing* on standard urban *Lots* having *Full Urban Services*. Lands must be designated as Low Density Residential under the *District's* Official Community Plan.

10.1.2 Principal Uses

The following *Uses* and no other *Uses* shall be the permitted *Principal Uses* in this zone subject to all applicable regulations of this Bylaw:

- (a) *Manufactured Housing - Type 1*; and
- (b) *Single Detached Housing*.

10.1.3 Accessory Uses

The following *Uses* and no other *Uses* shall be the permitted *Accessory Uses* in this zone subject to all applicable regulations of this Bylaw:

- (a) *Accessory Buildings and Structures*;
- (b) *Bed & Breakfast Home*;
- (c) *Carriage House*;
- (d) *Child Care Centre, Minor*;
- (e) *Group Home, Minor*;
- (f) *Home Occupation - Type 1 or 2*; and
- (g) *Secondary Suite*.

10.1.4 Subdivision Regulations

- (a) Minimum *Lot Area* 460m²
- (b) Minimum *Lot Width* 12.0m
- (c) Minimum *Lot Depth* 30.0m
- (d) Notwithstanding Section 10.1.4(c), the *Lot Depth* may be reduced to 20.0m for the purposes of subdividing *Corner Lots*.

10.1.5 Development Regulations

- (a) Maximum *Lot Coverage* 40 percent
- (b) Maximum *Floor Area Ratio* 0.45

10.1.6 Siting Regulations

Bylaw 2012-017 amended the following section a(iii) and b(iii) and (v) - (July 23rd, 2012):

- (a) Principal *Buildings* and *Structures*:
- | | | |
|-------|--|--|
| (i) | Minimum <i>Front Setback</i> | 6.0m |
| (ii) | Minimum <i>Rear Setback</i> | 7.5m |
| (iii) | Minimum <i>Side Setback (Interior)</i> | 1.5m (see vi) |
| (iv) | Minimum <i>Side Setback (Exterior)</i> | 4.5m |
| (v) | Maximum <i>Height</i> | The lesser of 9.5m or 2 <i>Storeys</i> |
| (vi) | Notwithstanding Section 10.1.6(a)(iii), a <i>Lot</i> having no direct vehicular access to the <i>Rear Yard</i> without an attached garage or <i>Carpport</i> shall maintain one <i>Side Yard Setback</i> of at least 3.0m. | |
- (b) *Accessory Buildings* and *Structures*
- | | | |
|-------|--|---|
| (i) | Minimum <i>Front Setback</i> | 6.0m |
| (ii) | Minimum <i>Rear Setback</i> | 1.5m |
| (iii) | Minimum <i>Side Setback (Interior)</i> | 1.5m (see vi) |
| (iv) | Minimum <i>Side Setback (Exterior)</i> | 4.5m |
| (v) | Maximum <i>Height</i> | The lesser of 4.5m or 1 <i>Storey (see vii)</i> |
| (vi) | Notwithstanding Section 10.1.6(b)(iii), a <i>Lot</i> having no direct vehicular access to the <i>Rear Yard</i> without an attached garage or <i>Carpport</i> shall maintain one <i>Side Yard Setback</i> of at least 3.0m. | |
| (vii) | Notwithstanding Section 10.1.6(b)(v), the maximum <i>Height</i> for an <i>Accessory Building</i> where a <i>Carriage House</i> is located over a garage is the lesser of 7.5m or 2 <i>Storeys</i> . | |

10.1.7 Other Regulations

- (a) Only one (1) principal *Dwelling* will be permitted per *Lot*.

Bylaw 2012-028 replaced the following definition (b) - (January 14th, 2013):

- (b) *Accessory Buildings* or *Structures* will be limited to a maximum of 75m² or 25% of the allowable *Lot* coverage, whichever is greater.
- (c) In addition to the regulations listed above, other regulations may apply. These include [Section 4: General Regulations](#), [Section 5: Landscaping and Screening Regulations](#), [Section 6: Parking and Loading Regulations](#), and

[Section 7: Specific Use Regulations.](#)

Bylaw 2014-018 added the following Section RSD1(i) -(September 8th, 2014):

10.2 RSD1(i) Residential Single Detached Intensive Zone RSD1(i)

10.2.1 Purpose

To provide a zone to accommodate the re-development of Single Detached Housing on small urban lots, close to the town centre, having Full Urban Services. This zone is intended to create infill opportunities. Lands must be designed as LDR(i) – Low Density Residential Intensification under the District’s Official Community Plan.

10.2.2 Principal Uses

The following Uses and no other Uses shall be the permitted Principal Uses in this zone subject to all applicable regulations of this Bylaw.

- (a) Manufactured Housing – type 1; and
- (b) Single Detached Housing.

10.2.3 Accessory Uses

The following Uses and no other Uses shall be the permitted Accessory Uses in this zone subject to all applicable regulations of this Bylaw.

- (a) Accessory Buildings and Structures;
- (b) Bed & Breakfast home;
- (c) Carriage Houses;
- (d) Child Care Centre, minor;
- (e) Home Occupation – type 1 or 2; and
- (f) Secondary Suites.

10.2.4 Subdivision Regulations

- (a) Minimum Lot Area 360m²
- (b) Minimum Lot Width 12.0m
- (c) Minimum Lot Depth 20.0m
- (d) Pursuant to Section 904 of the Local Government Act, and notwithstanding Sections 10.1.4 a) through d) of this Bylaw, if the owner of the land proposed to be subdivided pays to the District prior to the time of subdivision approval \$5,000 per additional Lot to be deposited in a reserve fund for parks, cultural

and recreational assets, and the necessary fire department equipment to service higher elevation Buildings, the following subdivision regulations shall apply:

- (i) Minimum Lot Area 275m²
- (ii) Minimum Lot Width 9.0m

Bylaw 2015-009 amended Section 10.2 RSD1(i) Residential Single Detached Intensive Zone to increase the lot coverage – adopted May 11th, 2015.

10.2.5 Development Regulations

- (a) Maximum Lot Coverage 40 percent
- (b) Maximum Floor Area Ratio 0.5

10.2.6 Siting Regulations

- (a) Principal Buildings and Structures
 - (i) Minimum Front Setback 6.0m
 - (ii) Minimum Rear Setback 6.0m
 - (iii) Minimum Side Setback (interior) 1.5m
 - (iv) Minimum Side Setback (exterior) 3.5m
 - (v) Maximum Height The lesser of 9.5m or 2 Storeys
 - (vi) Notwithstanding Section 10.1.6(a)(iii), a Lot having no direct Vehicular access to the Rear Yard without an attached garage or carport Shall maintain one Side Yard setback of at least 3.0m.

- (b) Accessory Buildings and Structures
 - (i) Minimum Front Setback 6.0m
 - (ii) Minimum Rear Setback 1.5m
 - (iii) Minimum Side Setback (interior) 1.5m
 - (iv) Minimum Side Setback (exterior) 4.5m
 - (v) Maximum Height The lesser of 4.5m or 1 Storey
 - (vi) Notwithstanding Section 10.1.6(b)(v), the maximum Height for an Accessory Building where a carriage house is located over a garage is the lesser of 7.5m or 2 Storeys.

10.2.7 Other Regulations

- (a) Only one (1) Principal Dwelling will be permitted per Lot.
- (b) Only two (2) Accessory Buildings or Structures shall be permitted per Lot with a maximum combined Gross Floor Area of 75.0m²
- (c) In addition to the regulations listed above, other regulations may apply. These include Section 4: General Regulations, Section 5: Landscaping and Screening Regulations, Section 6: Parking and Loading Regulations, and Section 7: Specific Use Regulations.

10.3 RSD2 Residential Large Lot Zone

RSD2

10.3.1 Purpose

To provide a zone to generally accommodate existing *Single Detached Housing Developments* on larger suburban *Lots* having *Full Urban Services*. Lands must be designated as Low Density Residential under the *District's* Official Community Plan.

10.3.2 Principal Uses

The following *Uses* and no other *Uses* shall be the permitted *Principal Uses* in this zone subject to all applicable regulations of this Bylaw:

- (a) *Manufactured Housing - Type 1*; and
- (b) *Single Detached Housing*.

10.3.3 Accessory Uses

The following *Uses* and no other *Uses* shall be the permitted *Accessory Uses* in this zone subject to all applicable regulations of this Bylaw:

- (a) *Accessory Buildings and Structures*;
- (b) *Bed & Breakfast Homes*;
- (c) *Carriage House* (where connected to *Full Urban Services*);
- (d) *Child Care Centre, Minor*;
- (e) *Group Home, Minor*;
- (f) *Home Occupation - Type 1 or 2*; and
- (g) *Secondary Suite*

10.3.4 Subdivision Regulations

- | | |
|------------------------------|-------------------|
| (a) Minimum <i>Lot Area</i> | 650m ² |
| (b) Minimum <i>Lot Width</i> | 18.0m |
| (c) Minimum <i>Lot Depth</i> | 30.0m |

10.3.5 Development Regulations

- | | |
|-------------------------------------|------------|
| (a) Maximum <i>Lot Coverage</i> | 40 percent |
| (b) Maximum <i>Floor Area Ratio</i> | 0.4 |

10.3.6 Siting Regulations

Bylaw 2012-017 amended the following section (a)(iii) and (b)(iii) and (v)-(July 23rd, 2012):

- (a) Principal *Buildings and Structures*:

- (i) Minimum *Front Setback* 6.0m
 - (ii) Minimum *Rear Setback* 7.5m
 - (iii) Minimum *Side Setback (Interior)* 1.5m (see vi)
 - (iv) Minimum *Side Setback (Exterior)* 4.5m
 - (v) Maximum *Height* The lesser of 9.5m or 2 *Storeys*
 - (vi) Notwithstanding Section 10.2.6(a)(iii), a *Lot* having no direct vehicular access to the *Rear Yard* without an attached garage or *Carport* shall maintain one *Side Yard Setback* of at least 3.0m.
- (b) *Accessory Buildings and Structures*
- (i) Minimum *Front Setback* 6.0m
 - (ii) Minimum *Rear Setback* 1.5m
 - (iii) Minimum *Side Setback (Interior)* 1.5m (see vi)
 - (iv) Minimum *Side Setback (Exterior)* 4.5m
 - (v) Maximum *Height* The lesser of 4.5m or 1 *Storey* (see vii)
 - (vi) Notwithstanding Section 10.2.6(b)(iii), a *Lot* having no direct vehicular access to the *Rear Yard* without an attached garage or *Carport* shall maintain one *Side Yard Setback* of at least 3.0m.
 - (vii) Notwithstanding Section 10.2.6(b)(v), the maximum *Height* for an *Accessory Building* where a *Carriage House* is located over a garage is the lesser of 7.5m or 2 *Storeys*.

10.3.7 Other Regulations

- (a) Only one (1) principal *Dwelling* will be permitted per *Lot*.

Bylaw 2012-028 replaced the following definition (b) - (January 14th, 2013):

- (b) *Accessory Buildings* or *Structures* will be limited to a maximum of 75m² or 25% of the allowable *Lot* coverage, whichever is greater.
- (c) In addition to the regulations listed above, other regulations may apply. These include [Section 4: General Regulations](#), [Section 5: Landscaping and Screening Regulations](#), [Section 6: Parking and Loading Regulations](#), and [Section 7: Specific Use Regulations](#).

10.4 RSD3 Residential Estate Lot Zone

RSD3

10.4.1 Purpose

To provide a zone to accommodate the *Development of Single Detached Dwellings* employing conventional subdivision designs on lands having *Full Urban Services* specifically in areas having topographical constraints. Lands must be designated as Low Density Residential under the *District's* Official Community Plan.

10.4.2 Principal Uses

The following *Uses* and no other *Uses* shall be the permitted *Principal Uses* in this zone subject to all applicable regulations of this Bylaw:

- (a) *Manufactured Housing - Type 1*; and
- (b) *Single Detached Housing*.

10.4.3 Accessory Uses

The following *Uses* and no other *Uses* shall be the permitted *Accessory Uses* in this zone subject to all applicable regulations of this Bylaw:

- (a) *Accessory Buildings and Structures*;
- (b) *Bed & Breakfast Home*;
- (c) *Carriage House* (where connected to *Full Urban Services*);
- (d) *Child Care Centre, Minor*;
- (e) *Group Home, Minor*;
- (f) *Home Occupation - Type 1 or 2*; and
- (g) *Secondary Suite*.

10.4.4 Subdivision Regulations

- | | | |
|-----|--------------------------|---------------------|
| (a) | Minimum <i>Lot Area</i> | 1,000m ² |
| (b) | Minimum <i>Lot Width</i> | 20.0m ² |
| (c) | Minimum <i>Lot Depth</i> | 35.0m |

10.4.5 Development Regulations

- | | | |
|-----|---------------------------------|------------|
| (a) | Maximum <i>Lot Coverage</i> | 30 percent |
| (b) | Maximum <i>Floor Area Ratio</i> | 0.35 |

10.4.6 Siting Regulations – *Principal Uses*

Bylaw 2012-017 amended the following section (a)(iii) and (b)(iii) and (v) - (July 23rd, 2012):

- (a) *Principal Buildings and Structures:*
- (i) Minimum *Front Setback* 7.0m
 - (ii) Minimum *Rear Setback* 7.5m
 - (iii) Minimum *Side Setback (Interior)* 1.5m (see vi)
 - (iv) Minimum *Side Setback (Exterior)* 4.5m
 - (v) Maximum *Height* The lesser of 9.5m or 2 *Storeys*
 - (vi) Notwithstanding Section 10.3.6(a)(iii), a *Lot* having no direct vehicular access to the *Rear Yard* shall maintain one *Side Yard Setback* of at least 3.0m.
- (b) *Accessory Buildings and Structures:*
- (i) Minimum *Front Setback* 7.0m
 - (ii) Minimum *Rear Setback* 1.5m
 - (iii) Minimum *Side Setback (Interior)* 1.5m (see vi)
 - (iv) Minimum *Side Setback (Exterior)* 4.5m
 - (v) Maximum *Height* The lesser of 4.5m of 1 *Storey* (see vii)
 - (vi) Notwithstanding Section 10.3.6(b)(iii), a *Lot* having no direct vehicular access to the *Rear Yard* shall maintain one *Side Yard Setback* of at least 3.0m.
 - (vii) Notwithstanding Section 10.3.6(b)(v), the maximum *Height* for an *Accessory Building* where a *Carriage House* is located over a garage is the lesser of 7.5m or 2 *Storeys*.

10.4.7 Other Regulations

- (a) Only one (1) principal *Dwelling* will be permitted per *Lot*.

Bylaw 2012-028 replaced the following definition (b) - (January 14th, 2013):

- (b) *Accessory Buildings or Structures* will be limited to a maximum of 75m² or 25% of the allowable *Lot* coverage, whichever is greater.
- (c) In addition to the regulations listed above, other regulations may apply. These include [Section 4: General Regulations](#), [Section 5: Landscaping and Screening Regulations](#), [Section 6: Parking and Loading Regulations](#), and

Section 7: Specific Use Regulations.

10.5 RDH Residential Duplex Housing Zone

RDH

10.5.1 Purpose

To provide a zone to accommodate the mixed *Development of Single Detached and Duplex Housing* within a neighbourhood having *Full Urban Services*. Lands must be designated as Low Density Residential under the *District's* Official Community Plan.

10.5.2 Principal Uses

The following *Uses* and no other *Uses* shall be the permitted *Principal Uses* in this zone subject to all applicable regulations of this Bylaw:

- (a) *Duplex Housing*;
- (b) *Manufactured Housing - Type 1*; and
- (c) *Single Detached Housing*.

10.5.3 Accessory Uses

The following *Uses* and no other *Uses* shall be the permitted *Accessory Uses* in this zone subject to all applicable regulations of this Bylaw:

- (a) *Accessory Buildings and Structures*;
- (b) *Bed & Breakfast Homes*;
- (c) *Carriage House, Accessory to Single Detached Housing*
- (d) *Child Care Centre, Minor*;
- (e) *Home Occupation - Type 1 or 2*; and
- (f) *Secondary Suite, Accessory to Single Detached Housing*.

10.5.4 Subdivision Regulations

- (a) Minimum *Lot Area – Single Detached Housing and Manufactured Housing* 650m²
- (b) Minimum *Lot Area – Duplex Housing* 850m²
- (c) Minimum *Lot Width – Single Detached Housing and Manufactured Housing* 18.0m
- (d) Minimum *Lot Width – Duplex Housing* 25.0m
- (e) Minimum *Lot Depth* 30.0m
- (f) Pursuant to Section 10.6.4 (a) and (b), where a *Lot* is to be subdivided for the purpose of creating individual ownership of side-by-side *Duplex Dwelling* units, the new *Lots* so created shall contain not less than one half (1/2) the minimum required *Lot Area* and minimum required *Lot Width* for *Duplex Housing*.

10.5.5 Development Regulations

- | | | |
|-----|---------------------------------|------------|
| (a) | Maximum <i>Lot Coverage</i> | 40 percent |
| (b) | Maximum <i>Floor Area Ratio</i> | 0.5 |

10.5.6 Siting Regulations

Bylaw 2012-017 amended the following section (a)(iii) and (b)(iii) and (v) - (July 23rd, 2012):

- (a) *Principal Buildings and Structures:*
- | | | |
|-------|--|---|
| (i) | Minimum <i>Front Setback</i> | 6.0m |
| (ii) | Minimum <i>Rear Setback</i> | 7.5m |
| (iii) | Minimum <i>Side Setback (Interior)</i> | 1.5m (see vi) |
| (iv) | Minimum <i>Side Setback (Exterior)</i> | 4.5m |
| (v) | Maximum <i>Height</i> | The lesser of 9.5m
or 2 <i>Storeys</i> |
- (vi) Notwithstanding Section 10.4.6(a)(iii), a *Lot* having no direct vehicular access to the *Rear Yard* without a garage or *Carport* shall maintain one *Side Setback* of at least 3.0m. In the case of a side-by-side duplex being subdivided for the purpose of creating individual ownership, the *Interior Side Setback* between the *Dwelling* units shall not be required provided the *Property Line* follows the centre line of the common party wall.
- (b) *Accessory Buildings and Structures*
- | | | |
|-------|--|---|
| (i) | Minimum <i>Front Setback</i> | 6.0m |
| (ii) | Minimum <i>Rear Setback</i> | 1.5m |
| (iii) | Minimum <i>Side Setback (Interior)</i> | 1.5m (see vi) |
| (iv) | Minimum <i>Side Setback (Exterior)</i> | 4.5m |
| (v) | Maximum <i>Height</i> | The lesser of 4.5m
or 1 <i>Storey</i> (see
vii) |
- (vi) Notwithstanding Section 10.4.6(b)(iii), a *Lot* having no direct vehicular access to the *Rear Yard* without a garage or *Carport* shall maintain one *Side Yard Setback* of at least 3.0m.

- (vii) Notwithstanding Section 10.4.6(b)(v), the maximum *Height* for an *Accessory Building* where a *Carriage House* is located over a garage is the lesser of 7.5m or 2 *Storeys*.

10.5.7 Other Regulations:

- (a) Only two (2) principal *Dwellings* will be permitted per *Lot* provided that both *Dwellings* are located in one (1) residential *Building*.

Bylaw 2012-028 replaced the following definition (b) - (January 14th, 2013):

- (b) *Accessory Buildings* or *Structures* will be limited to a maximum of 75m² or 25% of the allowable Lot coverage, whichever is greater.
- (c) In addition to the regulations listed above, other regulations may apply. These include [Section 4: General Regulations](#), [Section 5: Landscaping and Screening Regulations](#), [Section 6: Parking and Loading Regulations](#), and [Section 7: Specific Use Regulations](#).

Bylaw 2014-006 added the following Section RPN-Residential Pocket Neighbourhood Zone - (June 23rd, 2014):

10.6 RPN – Residential Pocket Neighbourhood Zone

RPN

10.6.1 Purpose

To provide a zone to accommodate the comprehensive *Development of Single Detached Housing* in a format which appears as a *Cluster* of cottages grouped around a shared open space and served by a shared parking area, on lands having Full Urban Services. Lands must be designated as LDR(i) – Low Density Residential (intensification) under the District’s Official Community Plan.

10.6.2 Principal Uses

The following *Uses* and no other *Uses* shall be permitted *Principal Uses* in this zone subject to all applicable regulations of the Bylaw.

- (a) Single Detached Housing.

10.6.3 Accessory Uses

The following *Uses* and no other *Uses* shall be the permitted *Accessory Uses* in this zone subject to all applicable regulations of this bylaw.

- (a) *Accessory Buildings and Structures* not exceeding 6.0m² in *Gross Floor Area*, per *Single Detached Dwelling*; and
- (b) *Home Occupation* – type 1.

10.6.4 Subdivision Regulations (Development Site)

- (a) Minimum Development Site Area 1,300m²
- (b) Minimum Development Site Width 36.0m
- (c) Minimum Development Site Depth 30.0m
- (d) Maximum Development Site Area 4,047m²

Bylaw 2016-018 deleted section (c) and renumbered accordingly - (May 24, 2016):

10.6.5 Development Regulations (*Development Site*)

- (a) Maximum *Lot Coverage* 40 percent

- (b) Maximum *Floor Area Ratio* 0.55
- (c) Maximum *Gross Floor Area* (individual Dwelling) 100m²

10.6.6 Siting Regulations (*Development Site*)

(a) *Principal Buildings and Structures:*

- (i) Minimum *Front Setback* 6.0m
- (ii) Minimum *Rear Setback* 6.0m
- (iii) Minimum *Side Setback (Interior)* 1.5m
- (iv) Minimum *Side Setback (Exterior)* 3.5m
- (v) Maximum *Height* The lesser of 7.0m or 1.5 Storeys

(b) *Accessory Buildings and Structures*

- (i) Minimum *Front Setback* 6.0m
- (ii) Minimum *Rear Setback* 1.5m
- (iii) Minimum *Side Setback (Interior)* 1.5m
- (iv) Minimum *Side Setback (Exterior)* 4.5m
- (v) Maximum *Height* The lesser of 4.5m or 1 Storey

10.6.7 Other Regulations

- (a) A minimum of 15 percent of the *Development* site shall be retained as *Amenity Space*.
- (b) Only one (1) *Accessory Building* or *Structure* will be allowed per *Principal Dwelling*.
- (c) No communal parking, loading or garbage collection facilities shall be permitted in any required yard *Abutting* a public *Highway*.

- (d) In addition to the regulations listed above, other regulations may apply. These include Section 4: General Regulations, Section 5: Landscaping and Screening Regulations, Section 6: Parking and Loading Regulations, and Section 7: Specific Use Regulations.

10.7 RSH Residential Strata Housing Zone

RSH

10.7.1 Purpose

To provide a zone to accommodate the comprehensive *Development of Single Detached Housing* in a bare land strata format which otherwise appears as a conventional residential subdivision on lands having *Full Urban Services*. Lands must be designated as Medium Density Residential under the *District's Official Community Plan*.

10.7.2 Principal Uses

The following *Uses* and no other *Uses* shall be permitted *Principal Uses* in this zone subject to all applicable regulations of the Bylaw:

- (a) *Single Detached Housing*.

10.7.3 Accessory Uses

The following *Uses* and no other *Uses* shall be the permitted *Accessory Uses* in this zone subject to all applicable regulations of this Bylaw:

- (a) *Accessory Buildings and Structures*;
- (b) *Child Care Centre, Minor*;
- (c) *Group Home, Minor*;
- (d) *Home Occupation - Type 1*; and
- (e) *Secondary Suite* on strata *Lots* with a minimum of 460m².

10.7.4 Subdivision Regulations

- (a) Minimum *Development Site Width* 40.0m
- (b) Minimum *Development Site Depth* 200m
- (c) Minimum *Strata Lot Area* 350m²

10.7.5 *Development* Regulations (Bareland Strata Lots)

- (a) Maximum *Lot Coverage* 40 percent
- (b) Maximum *Floor Area Ratio* 0.6

10.7.6 *Development* Regulations (Development Site)

- (a) Maximum *Lot Coverage* 40 percent
- (b) Maximum *Floor Area Ratio* 0.6m

10.7.7 Siting Regulations (*Development Site*)

Bylaw 2012-017 amended the following section (a)(iii) and (b)(iii) - (July 23rd, 2012):

- (a) *Principal Buildings and Structures:*
- (i) Minimum *Front Setback* 6.0m
 - (ii) Minimum *Rear Setback* 6.0m
 - (iii) Minimum *Side Setback (Interior)* 1.5m (see vi)
 - (iv) Minimum *Side Setback (Exterior)* 4.5m
 - (v) Maximum *Height* The lesser of 9.5m or 2 *Storeys*
 - (vi) Notwithstanding Section 10.5.7(a)(iii), a *Lot* having no direct vehicular access to the *Rear Yard* without a garage or *Carport* shall maintain one *Side Setback* of at least 3.0m.
- (b) *Accessory Buildings and Structures:*
- (i) Minimum *Front Setback* 6.0m
 - (ii) Minimum *Rear Setback* 1.5m
 - (iii) Minimum *Side Setback (Interior)* 1.5m (see vi)
 - (iv) Minimum *Side Setback (Exterior)* 4.5m
 - (v) Maximum *Height* The lesser of 4.5m or 1 *Storey*
 - (vi) Notwithstanding Section 10.5.7(b)(iii), a *Lot* having no direct vehicular access to the *Rear Yard* without a garage or *Carport* shall maintain one *Side Setback* of at least 3.0m.

10.7.8 Other Regulations

- (a) Only one (1) principal *Dwelling* will be permitted per strata *Lot*.
- (b) A minimum of 15 percent of the *Development Site* shall be retained as *Amenity Space*.
- (c) Only one (1) *Accessory Building* or *Structure* will be allowed per strata *Lot* site with a maximum *Gross Floor Area* of 45.0m².
- (d) No communal parking, loading or garbage collection facilities shall be permitted in any required yard *Abutting* a public *Highway*.
- (e) In addition to the regulations listed above, other regulations may apply.

These include [Section 4: General Regulations](#), [Section 5: *Landscaping and Screening Regulations*](#), [Section 6: Parking and Loading Regulations](#), and [Section 7: *Specific Use Regulations*](#).

10.8 RMD Residential Medium Density Zone

RMD

10.8.1 Purpose

To provide a zone to accommodate the *Development* of multiple housing units in close proximity to existing or proposed low *Density Developments* on lands having *Full Urban Services*. Lands must be designated as Medium Density Residential under the *District's* Official Community Plan.

10.8.2 Principal Uses

The following *Uses* and no other *Uses* shall be the permitted *Principal Uses* in this zone subject to all applicable regulations of this Bylaw:

- (a) *Cluster Housing* comprised of *Single Detached Housing, Duplex Housing, and /or Townhouse Housing*;
- (b) *Duplex Housing*; and
- (c) *Townhouse Housing*.

10.8.3 Accessory Uses

The following *Uses* and no other *Uses* shall be the permitted *Accessory Uses* in this zone subject to all applicable regulations of this Bylaw:

- (a) *Accessory Buildings and Structures*;
- (b) *Child Care Centre, Minor*; and
- (c) *Home Occupation - Type 1*.

10.8.4 Subdivision Regulations

- (a) Minimum *Lot Area* 1,100m²
- (b) Minimum *Lot Width* 30.0m
- (c) Minimum *Lot Depth* 30.0m

10.8.5 Development Regulations

- (a) Maximum *Lot Coverage* 40 percent
- (b) Maximum *Floor Area Ratio* 0.6
- (c) Pursuant to Section 904 of the Local Government Act, and notwithstanding Section 10.6.5(b) of this Bylaw, the maximum *Floor Area Ratio* may be increased to 0.8 if the owner of the land proposed to be developed pays to the *District* prior to the time of *Building Permit* issuance the amount equal to \$2.50 per square foot of additional *Gross Floor Area*, to be deposited in a reserve fund for parks, cultural and recreational assets, and the necessary

fire department equipment to service higher multiple *Storey Buildings*.

10.8.6 Siting Regulations

- (a) Principal *Buildings* and *Structures*
 - (i) Minimum *Front Setback* 6.0m
 - (ii) Minimum *Rear Setback* 7.5m
 - (iii) Minimum *Side Setback (Interior)* 4.0m
 - (iv) Minimum *Side Setback (Exterior)* 6.0m
 - (v) Maximum *Height* The lesser of 10.5m or 3 *Storeys*

- (b) *Accessory Buildings* and *Structures*:
 - (i) Minimum *Front Setback* 6.0m
 - (ii) Minimum *Rear Setback* 1.5m
 - (iii) Minimum *Side Setback (Interior)* 1.5m
 - (iv) Minimum *Side Setback (Exterior)* 6.0m
 - (v) Maximum *Height* The lesser of 4.5m or 1 *Storey*

10.8.7 Other Regulations

- (a) No parking, loading or garbage collection facilities shall be permitted in any required yard *Abutting* a public *Highway*.
- (b) A minimum area of 30.0m² of on-site *Amenity Space* shall be provided per *Dwelling*.
- (c) No more than 8 *Dwellings* may be located in a *Building*.
- (d) Notwithstanding Section 10.6.5(b) of this Bylaw, the minimum *Floor Area Ratio* may be increased to 0.8 if the owner of the land proposed to be developed pays to the *District* prior to the time of *Building Permit* issuance the amount equal to \$2.50 per square foot of additional *Gross Floor Area*.
- (e) In addition to the regulations listed above, other regulations may apply. These include [Section 4: General Regulations](#), [Section 5: Landscaping and Screening Regulations](#), [Section 6: Parking and Loading Regulations](#), and [Section 7: Specific Use Regulations](#).

10.9 RHD Residential High Density Zone

RHD

10.9.1 Purpose

To provide a zone to accommodate *Apartments* on lands having *Full Urban Services*. Lands must be designated as High Density Residential under the *District's* Official Community Plan.

10.9.2 Principal Uses

The following *Uses* and no other *Uses* shall be the permitted *Principal Uses* in this zone subject to all applicable regulations of this Bylaw:

- (a) *Apartment Housing*; and
- (b) *Cluster Housing* comprised of *Townhouse* and *Apartment Housing* units.

10.9.3 Accessory Uses

The following *Uses* and no other *Uses* shall be the permitted *Accessory Uses* in this zone subject to all applicable regulations of this Bylaw:

- (a) *Accessory Buildings and Structures*;
- (b) *Child Care Centres Minor or Major* provided they are operated from a communal *Amenity Space and Building*; and
- (c) *Home Occupation - Type 1*.

10.9.4 Subdivision Regulations

- | | | |
|-----|--------------------------|---------------------|
| (a) | Minimum <i>Lot Area</i> | 1,400m ² |
| (b) | Minimum <i>Lot Width</i> | 30.0m |
| (c) | Minimum <i>Lot Depth</i> | 30.0m |

10.9.5 Development Regulations

- | | | |
|-----|---|------------|
| (a) | Maximum <i>Lot Coverage</i> | 50 percent |
| (b) | Maximum <i>Floor Area Ratio</i> | 1.2 |
| (c) | Pursuant to Section 904 of the <u>Local Government Act</u> , and notwithstanding Section 10.7.5(b) of this Bylaw, the maximum <i>Floor Area Ratio</i> may be increased to 1.6 if the owner of the land proposed to be developed pays to the <i>District</i> prior to the time of <i>Building Permit</i> issuance the amount equal to \$2.50 per square foot of additional <i>Gross Floor Area</i> , to be deposited in a reserve fund for parks, cultural and recreational assets, and the necessary fire department equipment to service higher multiple <i>Storey Buildings</i> . | |

10.9.6 Siting Regulations

- (a) *Principal Buildings and Structures*
- (i) Minimum *Front Setback* 6.0m
 - (ii) Minimum *Rear Setback* – a *Building* not over 2 *Storeys* 7.5m
 - (iii) Minimum *Rear Setback* – a *Building* over 2 *Storeys* 9.0m
 - (iv) Minimum *Side Setback* – any portion of a *Building* under 2 *Storeys* in *Height* 4.0m
 - (v) Minimum *Side Setback* – any portion of a *Building* 2 *Storeys* or over in *Height* 6.0m
 - (vi) Maximum *Height* The lesser of 15.0m or 4 *Storeys*
 - (vii) Notwithstanding Section 10.7.6(a)(iv), a minimum *Side Yard Setback* of 6.0m shall be required for any *Property Line Abutting a Street*
- (b) *Accessory Buildings and Structures*
- (i) Minimum *Front Setback* 6.0m
 - (ii) Minimum *Rear Setback* 6.0m
 - (iii) Minimum *Side Setback (Interior)* 4.0m
 - (iv) Minimum *Side Setback (Exterior)* 6.0m
 - (v) Maximum *Height* The lesser of 4.5m or 1 *Storey*

10.9.7 Other Regulations

- (a) No commercial parking, loading or garbage collection facilities shall be permitted in any required yard *Abutting* a public *Highway*.
- (b) On-site *Amenity Space* shall be provided based on the sum total of the following class of *Dwellings* to be developed on the property:
 - (i) *Townhouses* 30.0m² per *Dwelling*.
 - (ii) *Apartments* 10.0m² per bachelor *Dwelling* plus 20.0m² per 1 *Bedroom Dwelling* plus 30.0m² per 2 or more *Bedroom*

Dwelling.

- (c) In addition to the regulations listed above, other regulations may apply. These include [Section 4: General Regulations](#), [Section 5: Landscaping and Screening Regulations](#), [Section 6: Parking and Loading Regulations](#), and [Section 7: Specific Use Regulations](#).

10.10 RMH Residential Manufactured Housing Zone

RMH

10.10.1 Purpose

To provide a zone to accommodate the *Development of Manufactured Homes* in a comprehensively designed community. Lands must be designated as Medium Density Residential under the *District's Official Community Plan*.

10.10.2 Principal Uses

The following *Uses* and no other *Uses* shall be the permitted *Principal Uses* in this zone subject to all applicable regulations of this Bylaw:

- (a) *Manufactured Housing - Type 1 or 2.*

10.10.3 Accessory Uses

The following *Uses* and no other *Uses* shall be the permitted *Accessory Uses* in this zone subject to all applicable regulations of this Bylaw:

- (a) *Accessory Buildings and Structures;*
- (b) *Child Care Centre, Minor;*
- (c) *Employee Housing; and*
- (d) *Home Occupation - type 1 or 2.*

10.10.4 Subdivision Regulations

- (a) Minimum *Development Site Area* 1.5ha
- (b) Minimum *Manufactured Housing Site Area – Single Section Homes* 350m²
- (c) Minimum *Manufactured Housing Site Area – Multiple Section Homes* 400m²
- (d) Minimum *Manufactured Housing Site Width – Single Section Homes on Interior Lots* 12.0m
- (e) Minimum *Manufactured Housing Site Width – Single Section Homes on Corner Lots* 15.0m
- (f) Minimum *Manufactured Housing Site Width – Multiple Section Homes on Interior Lots* 13.5m
- (g) Minimum *Manufactured Housing Site Width – Multiple Section Homes on Corner Lots* 15.0m
- (h) Minimum *Manufactured Housing Site Depth – Single Section Homes* 29.0m
- (i) Minimum *Manufactured Housing Site Depth* 27.0m

– Multiple Section Homes

10.10.5 *Development Regulations*

- (a) Maximum *Manufactured Housing Lot Coverage* 40 percent

10.10.6 *Siting Regulations – Principal and Accessory Uses (Manufactured Housing Site)*

- (a) Minimum *Front Setback* 4.5m
- (b) Minimum *Rear Setback* 1.5m
- (c) Minimum *Side Setback (Interior)* 1.5m
- (d) Minimum *Side Setback (Exterior)* 4.5m
- (e) Maximum *Height – Manufactured Housing* The lesser of 6.5m or 2 *Storeys*
- (f) Maximum *Height – Single Detached Dwelling* The lesser of 9.5m or 2 *Storeys*
- (g) Maximum *Height – Accessory Buildings or Structures* The lesser of 4.5m or 1 *Storey*
- (h) Notwithstanding Section 10.8.6 (a) through (c), a minimum *Setback* of 4.5m shall be provided for all *Buildings* and *Structures* on *Manufactured Housing Lots* flanking or backing onto the boundary of the *Manufactured Housing Community* or a minimum *Setback* of 6.0m for all *Buildings* and *Structures* on *Manufactured Housing Lots* fronting a public *Highway*.

10.10.7 *Other Regulations*

- (a) Only one (1) principal *Dwelling* will be permitted per *Manufactured Housing Lot*.
- (b) Only one (1) *Accessory Building* or *Structure* will be permitted per *Manufactured Housing Lot* with a maximum gloss floor area of 45.0m².
- (c) No *Parking Spaces* shall be permitted in any required *Front Yard* or *Exterior Side Yard Setback* of the *Development Site*.
- (d) For *Manufactured Housing Communities*, *Amenity Space* shall be provided in the amount of five percent of the total *Development Site*. For the purpose of calculating *Amenity Space*, any indoor common areas accessible to all of the *Manufactured Housing Community* residents shall be counted as double its actual *Gross Floor Area*.
- (e) *Manufactured Housing* units employing the CSA Z240.10.1 standard shall construct skirting that is stuccoed, factory fabricated or of equivalent

quality so that the finished design complements the exterior finish of *Dwelling*.

- (f) In addition to the regulations listed above, other regulations may apply. These include [Section 4: General Regulations](#), [Section 5: Landscaping and Screening Regulations](#), [Section 6: Parking and Loading Regulations](#), and [Section 7: Specific Use Regulations](#).
- (g) *Employee Housing* shall be limited to one (1) *Single Detached Dwelling* per *Development Site*.

11.0 Commercial Zones

11.1 CN Neighbourhood Commercial Zone

CN

11.1.1 To provide a zone to accommodate the day to day convenience shopping needs of local neighbourhoods. Lands must be designated as Low Density Residential, Medium Density Residential, or High Density Residential, under the *District's* Official Community Plan.

11.1.2 Principal Uses

The following *Uses* and no other *Uses* shall be the permitted *Principal Uses* in this zone subject to all applicable regulations of this Bylaw:

- (a) *Child Care Centre, Major, Minor;*
- (b) *Convenience Store;*
- (c) *community recreation service;*
- (d) *Dwelling;*
- (e) *Personal Service Establishment;*
- (f) *Recycle Drop-Off Centre; and*
- (g) *Single Detached Housing; and*

Bylaw 2012-001 replaced the following principal use:

- (h) *Manufacture and sales of sportswear and promotional products only on Lot 7, DL 474, ODYD, Plan 2679, located at 11402 Victoria Road.*

11.1.3 Accessory Uses

The following *Uses* and no other *Uses* shall be the permitted *Accessory Uses* in this zone subject to all applicable regulations of this Bylaw:

- (a) *Accessory Buildings & Structures.*

11.1.4 Subdivision Regulations

- (a) *Minimum Lot Area* 1,100m²
- (b) *Maximum Lot Area* 2,025m²
- (c) *Minimum Lot Width* 18.0m
- (d) *Minimum Lot Depth* 30.0m

11.1.5 Development Regulations

- (a) *Maximum Lot Coverage* 35 percent
- (b) *Maximum Floor Area Ratio* 0.7

11.1.6 Siting Regulations – Principal & Accessory Uses

Bylaw 2012-017 amended the following section (b) and (c) - (July 23rd, 2012):

- | | | |
|-----|--|---|
| (a) | Minimum <i>Front Setback</i> | 6.0m |
| (b) | Minimum <i>Rear Setback</i> | 3.5m (see (f)) |
| (c) | Minimum <i>Side Setback (Interior)</i> | 2.4m (see (f)) |
| (d) | Minimum <i>Side Setback (Exterior)</i> | 3.5m |
| (e) | Maximum <i>Height</i> | The lesser of 9.5m or
2 <i>Storeys</i> |
| (f) | Notwithstanding Section 11.1.6 (b) and (c), where a C1-Neighbourhood Commercial zoned <i>Lot Abuts</i> a rural residential zone or an urban residential zone described in column 1 of Table 3.1 of this Bylaw, the minimum <i>Rear Yard Setback</i> shall be 6.0m and the minimum <i>Interior Side Yard Setback</i> shall be 3.0m. | |

11.1.7 Other Regulations

- (a) A maximum of two (2) *Dwellings* shall be permitted per *Lot*. A separate entrance to the *Dwellings* must be maintained at *Finished Grade*.
- (b) Only one *Single Detached Dwelling* shall be permitted per *Lot*.
- (c) In addition to the regulations listed above, other regulations may apply. These include [Section 4: General Regulations](#), [Section 5: Landscaping and Screening Regulations](#), [Section 6: Parking and Loading Regulations](#), and [Section 7: Specific Use Regulations](#).

11.2 CT1 Tourist Commercial Zone

CT1

11.2.1 Purpose

To provide a zone to accommodate recreation-oriented tourist facilities and services for a number of unique commercial destination points within the community. Lands must be designated Tourist Commercial under the *District's* Official Community Plan.

11.2.2 Principal Uses

The following *Uses* and no other *Uses* shall be the permitted *Principal Uses* in this zone subject to all applicable regulations of this Bylaw:

- (a) art gallery & museum;
- (b) *Eating & Drinking Establishment*;
- (c) club;
- (d) *Hotel*;
- (e) *Marina*;
- (f) *Motel*;
- (g) *Personal Service Establishment*;
- (h) *Recreational Service, Indoor*;
- (i) *Recreation Service, Outdoor*;
- (j) *Retail Store, General*;
- (k) *Theatre*;
- (l) tourist railway operation; and
- (m) wine & beer store;

11.2.3 Accessory Uses

The following *Uses* and no other *Uses* shall be the permitted *Accessory Uses* in this zone subject to all applicable regulations of this Bylaw:

- (a) *Accessory Buildings and Structures*.

11.2.4 Subdivision Regulations

- (a) Minimum *Lot Area* 930m²
- (b) Minimum *Lot Width* 18.0m

11.2.5 *Development* Regulations

- (a) Maximum *Lot Coverage* 50 percent
- (b) Maximum *Floor Area Ratio* 1.0

11.2.6 Siting Regulations – *Principal & Accessory Uses*

- (a) Minimum *Front Setback* 2.5m
- (b) Minimum *Rear Setback* 6.0m
- (c) Minimum *Side Setback (Interior)* 0.0m
- (d) Minimum *Side Setback (Exterior)* 4.5m
- (e) Maximum *Height* The lesser of 9.5m or 2 *Storeys*
- (f) Notwithstanding Section 11.2.6(e), the maximum *Height* of the *Principal Building* may be increased to the lesser of 12.0m or 3 *Storeys* provided the third *Storey* is entirely integrated into the roof line of the *Building*.

11.2.7 Other Regulations

- (a) The maximum *Gross Floor Area* of each *Retail Store* shall be 100m².
- (b) In addition to the regulations listed above, other regulations may apply. These include [Section 4: General Regulations](#), [Section 5: Landscaping and Screening Regulations](#), [Section 6: Parking and Loading Regulations](#), and [Section 7: Specific Use Regulations](#).

11.3 CH Highway Commercial Zone

CH

11.3.1 Purpose

To provide a zone to predominantly accommodate *Highway*-oriented sales and services to the travelling public. *Lots* must be designated as Tourist Commercial under the *District's* Official Community Plan.

11.3.2 Principal Uses

The following *Uses* and no other *Uses* shall be the permitted *Principal Uses* in this zone subject to all applicable regulations of this Bylaw:

- (a) carwash;
- (b) *Convenience Store*;
- (c) fruit stand;
- (d) *Eating & Drinking Establishment*;
- (e) *Gas Bar*;
- (f) *Hotel*;
- (g) *Motel*;
- (h) *Club*;
- (i) *Protective & Emergency Services*;
- (j) *Recreational Services, Indoor*;
- (k) recreation vehicle sales, rental & service;
- (l) *Service Stations*;
- (m) tourism information centres; and
- (n) greenhouses and plant nurseries.

11.3.3 Accessory Uses

The following *Uses* and no other *Uses* shall be the permitted *Accessory Uses* in this zone subject to all applicable regulations of this Bylaw:

- (a) *Accessory Building & Structures*; and
- (b) wine & beer store.

11.3.4 Subdivision Regulations

- | | |
|------------------------------|-------------------|
| (a) Minimum <i>Lot Area</i> | 930m ² |
| (b) Minimum <i>Lot Width</i> | 25.0m |

11.3.5 Development Regulations

- (a) Maximum *Lot Coverage* 35 percent

11.3.6 Siting Regulations – *Principal & Accessory Uses*

Bylaw 2012-017 amended the following section (b) - (July 23rd, 2012):

- (a) Minimum *Front Setback* 7.0m
- (b) Minimum *Rear Setback* 3.0m (see (f))
- (c) Minimum *Side Setback (Interior)* 2.5m
- (d) Minimum *Side Setback (Exterior)* 4.5m
- (e) Maximum *Height* The lesser of 9.5m or 2 *Storeys*
- (f) Notwithstanding Section 11.3.6 (b), where a CT2 - Commercial Tourist zoned *Lot Abuts* an urban residential zoned *Lot* or an agricultural zoned *Lot* described in column 1 of [Table 3.1](#), the minimum *Rear Yard Setback* shall be 6.0m.

11.3.7 Other Regulations

- (a) Outdoor storage of machinery, equipment, materials, or vehicles under repair shall not be permitted.
- (b) In addition to the regulations listed above, other regulations may apply. These include [Section 4: General Regulations](#), [Section 5: Landscaping and Screening Regulations](#), [Section 6: Parking and Loading Regulations](#), and [Section 7: Specific Use Regulations](#).

11.4 CT2 Campground Zone

CT2

11.4.1 Purpose

To provide a zone to accommodate outdoor *Campground Uses*. Lands must be designated as Tourist Commercial under the *District's* Official Community Plan.

11.4.2 Principal Uses

The following *Uses* and no other *Uses* shall be the permitted *Principal Uses* in this zone subject to all applicable regulations of this Bylaw.

- (a) *Campgrounds*.

11.4.3 Accessory Uses

The following *Uses* and no other *Uses* shall be the permitted *Accessory Uses* in this zone subject to all applicable regulations of this Bylaw.

- (a) *Accessory Buildings and Structures*;
- (b) *Amusement Establishment for Campground guests*;
- (c) *Employee Housing*;
- (d) *Convenience Store for Campground guests*; and
- (e) *Recreational facilities for Campground guests*.

11.4.4 Subdivision Regulations

- | | | |
|-----|---------------------------------------|-------|
| (a) | Minimum <i>Development Site Area</i> | 1.0ha |
| (b) | Minimum <i>Development Site Width</i> | 60.0m |
| (c) | Minimum <i>Development Site Depth</i> | 100m |

11.4.5 Development Regulations

- | | | |
|-----|----------------------------------|--|
| (a) | Maximum <i>Density</i> | 50 camping lots or sites per hectare |
| (b) | Maximum <i>Lot Site Coverage</i> | 10 percent for permanent <i>Buildings & Structures</i> |
| (c) | <i>Floor Area Ratio</i> | 0.1 for <i>Accessory Uses</i> only |

11.4.6 Siting Regulations – Principal & Accessory Uses (Development Site Boundaries)

(a)	Minimum <i>Front Setback</i>	7.5m
(b)	Minimum <i>Rear Setback</i>	7.5m
(c)	Minimum <i>Side Setback (Interior)</i>	7.5m
(d)	Minimum <i>Side Setback (Exterior)</i>	7.5m
(e)	Maximum <i>Height</i>	The lesser of 9.5m or 2 <i>Storeys</i>

11.4.7 Other Regulations

- (a) *Employee Housing* shall be limited to one (1) *Dwelling* unit per *Lot* or *Development Site*.
- (b) All roads and services within the *Campgrounds* shall meet the regulations of the *District's* Subdivision & Development Servicing Bylaw.
- (c) In addition to the regulations listed above, other regulations may apply. These include [Section 4: General Regulations](#), [Section 5: Landscaping and Screening Regulations](#), [Section 6: Parking and Loading Regulations](#), and [Section 7: Specific Use Regulations](#).

11.5 CB1 Central Business Zone

CB1

11.5.1 Purpose

To provide a zone to accommodate a commercial and cultural focal point for the community, allowing town centre *Uses* including retail, *Office*, entertainment, and *Dwelling* units. Lands must be designated as Downtown Commercial under the *District's* Official Community Plan.

11.5.2 Principal Uses

The following *Uses* and no other *Uses* shall be the permitted *Principal Uses* in this zone subject to all applicable regulations of this Bylaw:

- (a) art gallery & museum;
- (b) *Amusement Establishment*;

Bylaw 2000-459 added the following definition (c) - (November 14, 2011):

- (c) *Animal Shelter, Minor*;
- (d) *Automotive & Equipment Repair Shop*;
- (e) *Business support services*;
- (f) *Education Services*;
- (g) community recreation;
- (h) *Club*;
- (i) *Convenience Store*;
- (j) *Apartment Housing*;
- (k) *Child Care Centre, Major, Minor*;
- (l) *Contractor Services, Limited*;
- (m) *Eating & Drinking Establishment*;
- (n) *Financial Services*;
- (o) *Funeral Home*;
- (p) *Health Services*;
- (q) *Hotel*;
- (r) library;
- (s) *Office*;
- (t) *Personal Service Establishment*;
- (u) *Place of Worship*;

- (v) *Protective and Emergency Services;*
- (w) *Retail Store, General;*
- (x) *Service Station;*
- (y) *Theatre;*
- (z) *Veterinary Clinic;*
- (aa) wine & beer store, and

Bylaw 2013-015 added the following definition (bb) - (June 24, 2013):

- (bb) Recreational Service, Indoor.

11.5.3 Accessory Uses

The following *Uses* and no other *Uses* shall be the permitted *Accessory Uses* in this zone subject to all applicable regulations of this Bylaw:

- (a) *Accessory Buildings & Structures;*
- (b) *Recycle Drop-Off Centres.*

11.5.4 Subdivision Regulations

- | | | |
|-----|--------------------------|-------------------|
| (a) | Minimum <i>Lot Area</i> | 140m ² |
| (b) | Minimum <i>Lot Width</i> | 7.5m |
| (c) | Maximum <i>Lot Width</i> | 24.0m |

11.5.5 *Development* Regulations

- | | | |
|-----|---|-------------|
| (a) | Maximum <i>Lot Coverage</i> | 100 percent |
| (b) | Maximum <i>Floor Area Ratio</i> | 2.5 |
| (c) | Pursuant to Section 904 of the <u>Local Government Act</u> , and notwithstanding Section 11.5.5(b), the maximum <i>Floor Area Ratio</i> may be increased to 3.5 if the owner of the land proposed to be developed pays to the <i>District</i> prior to the time of <i>Building Permit</i> issuance the amount equal to \$4.00 per square foot of additional <i>Gross Floor Area</i> , to be deposited in a reserve fund for parks, cultural and recreational assets, and the necessary fire department equipment to service higher multiple <i>Storey Buildings</i> . | |

11.5.6 Siting Regulations – Principal & Accessory

- | | | |
|-----|--|------|
| (a) | Minimum <i>Front Setback</i> | 0.0m |
| (b) | Minimum <i>Rear Setback</i> | 0.0m |
| (c) | Minimum <i>Side Setback (Interior)</i> | 0.0m |

- (d) Minimum *Side Setback (Exterior)* 0.0m
- (e) Maximum *Height* The lesser of
15.0m or 4 *Storeys*
- (f) Notwithstanding Section 11.5.6, where a *Lot Abuts a Highway* intersection, the required *Setback* for the *First Storey Adjacent* to the intersection shall accommodate an unobstructed *Site Triangle*, each such point forming the *Site Triangle* in this instance being 4.5m from the point of intersection.

11.5.7 *Mixed Use and Dwelling Regulations*

- (a) The *Frontage* width of individual commercial retail units shall not exceed 16.0m.
- (b) All *Dwelling* units shall be provided with an *at-Grade* entrance separate from the non-residential *Uses*; where such an entrance fronts onto a public *Street*, said entrance may not exceed 5.0m in width.
- (c) All *Apartments* must be located either on a separate *Storey* above the non-residential *Uses* or on the same *Storey* as the non-residential *Uses*, provided that no more than 40 percent of the *Gross Floor Area* of the *First Storey* is occupied by *Apartments* and that no *Apartments* face *Front Property Lines* along the following *Streets*:
 - (i) Victoria Road (from Hunt Street to Jubilee Road)
 - (ii) Jubilee Road (from Dickson Avenue to Kelly Avenue)
 - (iii) Main Street (from Victoria Road to Rosedale Avenue)
- (d) Ground floor *Apartments* may include live-work space that combines *Dwelling* space with commercial space, provided that such *Apartments* face *Front Property Lines* along the following public *Streets*:
 - (i) Wharton Street (from Victoria Road/Hunt Street to Rosedale Avenue)

11.5.8 Other Regulations

- (a) In addition to the regulations listed above, other regulations may apply. These include [Section 4: General Regulations](#), [Section 5: Landscaping and Screening Regulations](#), [Section 6: Parking and Loading Regulations](#), and [Section 7: Specific Use Regulations](#).

11.6 CB2 Shopping Centre Zone

CB2

11.6.1 Purpose

To provide a zone to accommodate retail, *Business*, entertainment and personal service *Uses* within a *Shopping Centre* environment. Lands must be designated as Downtown Commercial under the *District's* Official Community Plan.

11.6.2 Principal Uses

The following *Uses* and no other *Uses* shall be the permitted *Principal Uses* in this zone subject to all applicable regulations of this Bylaw:

(a) *Amusement Establishment;*

Bylaw 2000-459 added the following definition (b) - (November 14, 2011):

- (b) *Animal Shelter, Minor;*
- (c) *Business support services;*
- (d) *Education Services;*
- (e) *Club;*
- (f) *Convenience Store;*
- (g) *Apartment Housing;*
- (h) *Eating & Drinking Establishment;*
- (i) *Financial Services;*
- (j) *Gas Bar;*
- (k) *Health Services;*
- (l) *Office;*
- (m) *Personal Service Establishment;*
- (n) *Protective & Emergency Services;*
- (o) *Recreational Services, Indoor;*
- (p) *Retail Store, General;*
- (q) *Theatre;*
- (r) *Veterinary Clinic; and*
- (s) *wine & beer store;*

11.6.3 Accessory Uses

The following *Uses* and no other *Uses* shall be the permitted *Accessory Uses* to a *Shopping Centre* subject to all applicable regulations of this Bylaw.

- (a) *Accessory Buildings & Structures;*
- (b) *Recycle Drop-Off Centre; and*
- (c) *Recreational Services, Outdoor.*

11.6.4 Subdivision Regulations

- | | | |
|-----|--------------------------|---------------------|
| (a) | Minimum <i>Lot Area</i> | 1,300m ² |
| (b) | Minimum <i>Lot Width</i> | 25.0m |
| (c) | Minimum <i>Lot Depth</i> | 40.0m |

11.6.5 *Development* Regulations

- | | | |
|-----|---------------------------------|------------|
| (a) | Maximum <i>Lot Coverage</i> | 35 percent |
| (b) | Maximum <i>Floor Area Ratio</i> | 0.7 |

11.6.6 Siting Regulations

Bylaw 2012-017 amended the following sections (b) and (c) - (July 23rd, 2012):

- | | | |
|-----|--|---|
| (a) | Minimum <i>Front Setback</i> | 6.0m |
| (b) | Minimum <i>Rear Setback</i> | 3.5m (see (f)) |
| (c) | Minimum <i>Side Setback (Interior)</i> | 3.5m (see (f)) |
| (d) | Minimum <i>Side Setback (Exterior)</i> | 2.4m |
| (e) | Maximum <i>Height</i> | The lesser of 9.5m
or 2 <i>Storeys</i> |
| (f) | Notwithstanding Section 11.6.6 (b) and (c), where a CB2 - Central Business zoned <i>Lot Abuts</i> an urban residential zoned <i>Lot</i> described in column 1 of Table 3.1 , the minimum <i>Rear Yard Setback</i> shall be 6.0m and the minimum <i>Interior Side Yard Setback</i> shall be 3.0m. | |

11.6.7 Other Regulations

- (a) All *Apartments* shall be provided with an at-*Grade* entrance separate from the non-residential *Uses*. Where such an entrance fronts onto a public *Street*, said entrance may not exceed 5.0m in width.
- (b) All *Apartments* must be located either on a separate *Storey* above the non-residential *Uses* or on the same *Storey* as the non-residential *Uses*, provided that no more than 40 percent of the *Gross Floor Area* of the first *Storey* is occupied by *Apartment Uses* and that no *Apartments* face *Front Property Lines* along the following public *Streets*:
 - (i) Highway #97

- (ii) Prairie Valley Road
- (c) In addition to the regulations listed above, other regulations may apply. These include [Section 4: General Regulations](#), [Section 5: Landscaping and Screening Regulations](#), [Section 6: Parking and Loading Regulations](#), and [Section 7: Specific Use Regulations](#).

11.7 CM Heavy Commercial Zone

CM

11.7.1 Purpose

To provide a zone to accommodate established commercial operations that require substantial on-site storage facilities. Lands must be designated as Service Commercial under the *District's* Official Community Plan.

11.7.2 Principal Uses

The following *Uses* and no other *Uses* shall be the permitted *Principal Uses* in this zone subject to all applicable regulations of this Bylaw:

- (a) cannery;
- (b) farm supplies, sales & storage;
- (c) garden centre;
- (d) lumber yard;
- (e) packing house; and
- (f) *Warehouse Sales Establishments*.

11.7.3 Accessory Uses

The following *Uses* and no other *Uses* shall be the permitted *Accessory Uses* in this zone subject to all applicable regulations of this Bylaw:

- (a) *Accessory Buildings & Structures*; and
- (b) *Employee Housing*.

11.7.4 Subdivision Regulations

- (a) Minimum *Lot Area* 5.0ha
- (b) Minimum *Lot Width* 100m

11.7.5 Development Regulations

- (a) Maximum *Lot Coverage* 60 percent

11.7.6 Siting Regulations – Principal and Accessory Uses

Bylaw 2012-017 amended the following sections (b) and (c) - (July 23rd, 2012):

- (a) Minimum *Front Setback* 6.0m
- (b) Minimum *Rear Setback* 3.0m (see (f))
- (c) Minimum *Side Setback (Interior)* 2.4m (see (f))

- (d) Minimum *Side Setback (Exterior)* 4.5m
- (e) Maximum *Height* The lesser of
12.0m or 2 *Storeys*
- (f) Notwithstanding Section 11.7.6 (b) and (c), where a CM - Heavy Commercial zoned *Lot Abuts* an urban residential zoned *Lot* described in column 1 of [Table 3.1](#), the minimum *Rear Yard Setback* shall be 6.0m and the minimum *Interior Side Yard Setback* shall be 3.0m.

11.7.7 Other Regulations

- (a) *Employee Housing* shall be limited to one (1) *Dwelling* unit per Lot or *Development Site*.
- (b) All *Employee Housing* shall be provided with an at-*Grade* entrance separate from the non-residential spaces; where such an entrance fronts onto a public *Street*, said entrance may not exceed 5.0m in width.
- (c) In addition to the regulations listed above, other regulations may apply. These include [Section 4: General Regulations](#), [Section 5: Landscaping and Screening Regulations](#), [Section 6: Parking and Loading Regulations](#), and [Section 7: Specific Use Regulations](#).

12.0 Industrial Zones

12.1 M1 Light Industrial Zone

M1

12.1.1 Purpose

To provide a zone to accommodate light industrial *Uses* and the processing of *Agriculture Products*. Lands must be designated as Light Industrial under the *District's* Official Community Plan.

12.1.2 Principal Uses

Bylaw 2012-027 added the following definition (p) - (January 14th, 2013):

The following *Uses* and no other *Uses* shall be the permitted *Principal Uses* in this zone subject to all applicable regulations of this Bylaw:

- (a) *Automotive & Equipment Repair Shop;*
- (b) *Contractor Services, Limited;*
- (c) *Eating & Drinking Establishment;*
- (d) *Equipment Rental;*
- (e) farm equipment sales and rental;
- (f) *Protective & Emergency Services;*
- (g) farm supplies, sales & storage;
- (h) indoor manufacturing operations;

Bylaw 2013-008 amended the following definition (12.1.2(i) - (April 29th, 2013):

- (i) primary & secondary processing of *Agriculture Products* excluding *abattoirs*;
- (j) *Recycle Drop-Off Centre;*
- (k) *Recycling Depot;*
- (l) research centre and laboratory;
- (m) *Winery & Cidery;*
- (n) *Brewing & Distilling;* and
- (o) *Commercial Storage.*
- (p) single detached housing as a permitted use for Lot A, District Lot 2194, ODYD, Plan KAP45982 being 18217 Bentley Road and Lot 1, District Lot 2194, ODYD, Plan 38005 being 18219 Bentley Road, only.

12.1.3 Accessory Uses

The following *Uses* and no other *Uses* shall be the permitted *Accessory Uses* in this zone subject to all applicable regulations of this Bylaw:

- (a) *Accessory Buildings and Structures*;
- (b) indoor display areas, retail sales areas and/or *Office* areas; and
- (c) *Employee Housing*.

12.1.4 Subdivision Regulations

Bylaw 2012-017 amended the following - (July 23rd, 2012):

- (a) Minimum *Lot Area (with sewer service)* 1,800m²
- (b) Minimum *Lot Area (without sewer service)* 1.0ha
- (c) Minimum *Lot Width* 30.0m

12.1.5 Development Regulations

- (a) Maximum *Lot Coverage* 60 percent

12.1.6 Siting Regulations – *Principal & Accessory Uses*

- (a) Minimum *Front Setback* 7.0m
- (b) Minimum *Rear Setback* 0.0m
- (c) Minimum *Side Setback (Interior)* 5.0m
- (d) Minimum *Side Setback (Exterior)* 5.0m
- (e) Maximum *Height* The lesser of
12.0m or 2 *Storeys*
- (f) Notwithstanding Section 12.1.6 (b), where the *Rear Yard Abuts* any zone other than an industrial zone, the *Rear Yard Setback* shall be 7.5m.
- (g) Notwithstanding Section 12.1.6 (c), where one *Interior Side Setback* measures at least 5.0m, the other *Interior Side Setback* may be reduced to 0.0m, provided that it *Abuts* an industrial zone.

12.1.7 Other Regulations

- (a) *Eating & Drinking Establishments* shall have a maximum *Gross Floor Area* of 100m² and shall not include *Premises* licensed under the Liquor Control and Licensing Act.
- (b) Indoor display areas, retail sales areas and/or *Office* areas shall occupy no more than 25 percent of the *Gross Floor Area* devoted to the *Principal Use*.
- (c) *Employee Housing* shall be limited to one (1) *Dwelling* unit per *Lot* or *Development Site*, which may include:

- (i) one *Apartment* situated within the principal *Building*; or
 - (ii) one *Manufactured Home*, if on a site greater than 2.0ha.
- (d) Where a *Lot* zoned M1 *Abuts Lots* zoned for non-industrial *Uses*, no *Use* shall direct illumination, light, or glare beyond the boundary of the *Lot* on which the *Use* is located.
- (e) In addition to the regulations listed above, other regulations may apply. These include [Section 4: General Regulations](#), [Section 5: Landscaping and Screening Regulations](#), [Section 6: Parking and Loading Regulations](#), and [Section 7: Specific Use Regulations](#).

12.2 M2 Heavy Industrial Zone

M2

12.2.1 Purpose

To provide a zone to accommodate more intensive industrial *Uses* as well as service commercial, light industrial and storage *Uses*. Lands must be designated as Medium Industrial under the *District's* Official Community Plan.

12.2.2 Principal Uses

The following *Uses* and no other *Uses* shall be the permitted *Principal Uses* in this zone subject to all applicable regulations of this Bylaw:

Bylaw 2000-459 amended the following Uses (a) - (November 14, 2011):

- (a) *Animal Shelter, Major;*
- (b) *Auctioneering Establishment;*
- (c) *Automobile Sales & Rentals;*
- (d) *Automotive & Equipment Repair Shop;*
- (e) *Autobody Repair Shop;*
- (f) *Bulk Fuel Depot;*
- (g) *Commercial Storage;*
- (h) *Contractor Services, General;*
- (i) *Contractor Services, Limited;*
- (j) *crematorium;*
- (k) *Eating & Drinking Establishment;*
- (l) *Equipment Rental;*
- (m) *farm equipment sales and rental;*
- (n) *farm supplies, sales & storage;*
- (o) *Fleet Service;*
- (p) *garden & farm supply sales;*
- (q) *General Industrial Uses;*
- (r) *indoor manufacturing operations;*

Bylaw 2013-008 amended the following definition (12.2.2(s) - April 29th, 2013):

- (s) *primary & secondary processing of Agriculture Products, excluding Abattoirs;*
- (t) *Recycle Drop-Off Centre;*

- (u) *Recycling Depot;*
- (v) *research centre and laboratory;*
- (w) *sawmill;*
- (x) *Service Station;*
- (y) *Storage Yard;*
- (z) *Warehouse Sales Establishment;*
- (aa) *Winery & Cidery;*
- (bb) *Brewing & Distilling;* and
- (cc) *Wrecking Yards.*

12.2.3 Accessory Uses

The following *Uses* and no other *Uses* shall be the permitted *Accessory Uses* in this zone subject to all applicable regulations of this Bylaw:

- (a) *Accessory Buildings & Structures;*
- (b) *indoor display areas, retail sales areas and/or Office areas;* and
- (c) *Employee Housing.*

12.2.4 Subdivision Regulations

Bylaw 2012-017 amended the following - (July 23rd, 2012):

- | | | |
|-----|---|---------------------|
| (a) | <i>Minimum Lot Area (with sewer service)</i> | 1,800m ² |
| (b) | <i>Minimum Lot Area (without sewer service)</i> | 1.0ha |
| (c) | <i>Minimum Lot Width</i> | 30.0m |

12.2.5 Development Regulations

- | | | |
|-----|-----------------------------|------------|
| (a) | <i>Maximum Lot Coverage</i> | 60 percent |
|-----|-----------------------------|------------|

12.2.6 Siting Regulations – *Principal & Accessory Uses*

- | | | |
|-----|---|-------------------------------------|
| (a) | <i>Minimum Front Setback</i> | 7.0m |
| (b) | <i>Minimum Rear Setback</i> | 0.0m |
| (c) | <i>Minimum Side Setback (Interior)</i> | 5.0m |
| (d) | <i>Minimum Side Setback (Exterior)</i> | 5.0m |
| (e) | <i>Maximum Height</i> | The lesser of
14.0m or 2 Storeys |
| (f) | <i>Notwithstanding Section 12.2.6 (b), where the Rear Yard Abuts any zone other than an industrial zone, the Rear Yard Setback shall be 7.5m.</i> | |

- (g) Notwithstanding Section 12.2.6 (c), where one *Interior Side Setback* measures at least 5.0m, the other *Interior Side Setback* may be reduced to 0.0m, provided that it *Abuts* an industrial zone.

12.2.7 Other Regulations

- (a) *Eating & Drinking Establishments* shall have a maximum *Gross Floor Area* of 100m² and shall not include *Premises* licensed under the [Liquor Control and Licensing Act](#).
- (b) Indoor display areas, retail sales areas and/or *Office* areas shall not occupy more than 25 percent of the *Gross Floor Area* devoted to the *Principal Use*.
- (c) *Employee Housing* shall be limited to one (1) *Dwelling* unit per *Lot* or *Development Site*, which may include:
 - (i) one *Apartment* situated within the *Principal Building*; or
 - (ii) one *Manufactured Home*, if on a site greater than 2.0ha.
- (d) Where a *Lot* zoned M2 *Abuts* *Lots* zoned for non-industrial *Uses*, no *Use* shall direct illumination, light, or glare beyond the boundary of the *Lot* on which the *Use* is located.
- (e) In addition to the regulations listed above, other regulations may apply. These include [Section 4: General Regulations](#), [Section 5: Landscaping and Screening Regulations](#), [Section 6: Parking and Loading Regulations](#), and [Section 7: Specific Use Regulations](#).

12.3 M3 Agri-Industrial Zone

M3

12.3.1 Purpose

To provide a zone to accommodate agricultural processing on lands which are situated within the *Agricultural Land Reserve* or are otherwise isolated from established industrial sectors within the community. Lands must be designated as Agri-Industrial under the *District's* Official Community Plan.

12.3.2 Principal Uses

The following *Uses* and no other *Uses* shall be the permitted *Principal Uses* in this zone subject to all applicable regulations of this Bylaw:

- (a) *Agriculture, General*;
- (b) greenhouses & plant nurseries;
- (c) packaging, packing, preserving, bottling, and freezing;

Bylaw 2013-008 amended the following definition (12.3.2(d) - April 29th, 2013):

- (d) primary & secondary processing of *Agriculture Products* excluding *abattoirs*;
- (e) research centre and laboratory; and
- (f) *Winery & Cidery*.

12.3.3 Accessory Uses

The following *Uses* and no other *Uses* shall be the permitted *Accessory Uses* in this zone subject to all applicable regulations of this Bylaw:

- (a) *Accessory Buildings and Structures*;
- (b) indoor display areas, retail sales areas and/or *Office* areas; and
- (c) *Employee Housing*.

12.3.4 Subdivision Regulations

Bylaw 2012-017 amended the following - (July 23rd, 2012):

- | | | |
|-----|---|---------------------|
| (a) | Minimum <i>Lot Area (with sewer service)</i> | 1,800m ² |
| (b) | Minimum <i>Lot Area (without sewer service)</i> | 1.0ha |
| (c) | Minimum <i>Lot Width</i> | 30.0m |

12.3.5 Development Regulations

- (a) Maximum *Lot Coverage* 10 percent
- (b) Notwithstanding Section 12.3.5 (a), a *Lot* for which the *Principal Use* is greenhouse, plant nurseries, primary & secondary processing of *Agriculture Products* and/or *Wineries* or *Cideries* may increase the

maximum *Lot Coverage* to 65 percent.

12.3.6 Siting Regulations – *Principal & Accessory Uses*

(a)	Minimum <i>Front Setback</i>	15.0m
(b)	Minimum <i>Rear Setback</i>	15.0m
(c)	Minimum <i>Side Setback (Interior)</i>	5.0m
(d)	Minimum <i>Side Setback (Exterior)</i>	10.0m
(e)	Maximum <i>Height</i>	The lesser of 11.0m or 2 <i>Storeys</i>

12.3.7 Other Regulations

- (a) Indoor display areas, retail sales areas and/or *Office* areas shall not occupy more than 25 percent of the *Gross Floor Area* devoted to the *Principal Use*.
- (b) *Employee Housing* shall be limited to one (1) *Dwelling* unit per *Lot* or *Development Site*, which may include:
 - (i) One *Apartment* situated within the *Principal Building*; or
 - (ii) One *Manufactured Home*, if on a site greater than 2.0ha.
- (c) Where a *Lot* zoned M3 *Abuts Lots* zoned for non-industrial *Uses*, no *Use* shall direct illumination, light, or glare beyond the boundary of the *Lot* on which the *Use* is located.
- (d) In addition to the regulations listed above, other regulations may apply. These include [Section 4: General Regulations](#), [Section 5: Landscaping and Screening Regulations](#), [Section 6: Parking and Loading Regulations](#), and [Section 7: Specific Use Regulations](#).

12.4 M4 Resource Industrial Zone

M4

12.4.1 Purpose

To provide a zone to accommodate resource-based industrial operations. Lands must be designated as Resource Industrial under the *District's* Official Community Plan.

12.4.2 Principal Uses

The following *Uses* and no other *Uses* shall be the permitted *Principal Uses* in this zone subject to all applicable regulations of this Bylaw:

- (a) concrete & asphalt plant;
- (b) *Natural Resource Extraction* operations;
- (c) solid waste & composting facility; and
- (d) *Storage Yard* for aggregate materials.

12.4.3 Accessory Uses

The following *Uses* and no other *Uses* shall be the permitted *Accessory Uses* in this zone subject to all applicable regulations of this Bylaw:

- (a) *Accessory Buildings and Structures*;
- (b) indoor display areas, retail sales areas and/or *Office* areas; and
- (c) *Employee Housing*.

12.4.4 Subdivision Regulations

- (a) Minimum *Lot Area* 2.0ha
- (b) Minimum *Lot Width* 100m

12.4.5 Development Regulations

- (a) Maximum *Lot Coverage* 10 percent

12.4.6 Siting Regulations – *Principal & Accessory Uses*

- (a) Minimum *Front Setback* 30.0m
- (b) Minimum *Rear Setback* 15.0m
- (c) Minimum *Side Setback (Interior)* 7.5m
- (d) Minimum *Side Setback (Exterior)* 7.5m
- (e) Maximum *Height* 18.0m

12.4.7 Other Regulations

- (a) Indoor display areas, retail sales areas and/or *Office* areas shall not occupy more than 25 percent of the *Gross Floor Area* devoted to the *Principal Use*.
- (b) *Employee Housing* shall be limited to one (1) *Dwelling* unit per *Lot* or *Development Site*, which may include:
 - (i) one *Apartment* situated within the *Principal Building*; or
 - (ii) one *Manufactured Home*, if on a site greater than 2.0ha.
- (c) Where a *Lot* zoned M4 *Abuts Lots* zoned for non-industrial *Uses*, no *Use* shall direct illumination, light or glare beyond the boundary of any *Lot* zoned M4.
- (d) In addition to the regulations listed above, other regulations may apply. These include [Section 4: General Regulations](#), [Section 5: Landscaping and Screening Regulations](#), [Section 6: Parking and Loading Regulations](#), and [Section 7: Specific Use Regulations](#).

12.5 M1-A Business Industrial Zone

12.5.1 Purpose

The purpose is to provide a zone to accommodate business industrial development containing clean industrial and businesses that provide services and support to industrial uses with limited outdoor storage and to provide for a transition to clean industrial uses.

12.5.2 Principal Uses

The following Uses and no other Uses shall be the permitted Principal Uses in this zone subject to all applicable regulations of this Bylaw:

- (a) Animal Shelter, Minor;
- (b) Automotive & Equipment Repair Shop;
- (c) Brewing & Distilling;
- (d) Broadcasting Studios;
- (e) Business support service;
- (f) Private Club;
- (g) Contractor Services, Limited;
- (h) Eating & Drinking Establishment;
- (i) Equipment Rental;
- (j) Farm equipment sales and rental;
- (k) Farm supplies, sales & storage;
- (l) Garden centre;
- (m) Indoor manufacturing operations;
- (n) Industrial high technology research and product design;
- (o) Primary & secondary processing of Agriculture Products, excluding abattoir;
- (p) Protective & Emergency Services;
- (q) Recreational Service, Indoor;
- (r) Recycling Depot;
- (s) Research centre and laboratory;
- (t) Warehouse Sales Establishment; and
- (u) Winery & Cidery.

12.5.3 Accessory Uses

The following Uses and no other Uses shall be the permitted Accessory Uses in this zone subject to all applicable regulations of this Bylaw:

- (a) Accessory Buildings and Structures;
- (b) Education Service;
- (c) Indoor display areas, retail sales areas and/or Office areas;
- (d) Employee Housing; and
- (e) Recycle Drop-Off Centre.

12.5.4 Subdivision Regulations

- (a) Minimum Lot Area (with sewer service) 1800m²
- (b) Minimum Lot Area (without sewer service) 1.0ha
- (c) Minimum Lot Width 30.0m

12.5.5 Development Regulations

- (a) Maximum Lot Coverage 60 percent

12.5.6 Siting Regulations – Principal and Accessory Uses

- (a) Minimum Front Setback 7.0m
- (b) Minimum Rear Setback 0.0m
- (c) Minimum Side Setback (interior) 5.0m
- (d) Minimum Side Setback (exterior) 5.0m
- (e) Maximum Height 14.0m

- (f) Notwithstanding Section 12.1.6(b), where the Rear Yard Abuts any zone other than an industrial zone, the Rear Yard Setback shall be 7.5m.

- (g) Notwithstanding Section 12.1.6(c), where one Interior Side Setback measures at least 5.0m, the other Interior Side Setback may be reduced to 0.0m, provided that it abuts an industrial zone.

12.5.7 Other Regulations

- (a) Eating & Drinking Establishments shall have a maximum Gross Floor Area of 100m² and shall not include Premises licensed under the Liquor Control and Licensing Act.
- (b) Indoor display areas, retail sales areas and/or Office areas shall occupy no more than 25 percent of the Gross Floor Area devoted to the Principal Use.
- (c) *Employee Housing* shall be limited to one (1) *Dwelling* unit per *Lot* or *Development Site*, which may include:
 - (i) One *Apartment* situated within the principal *Building*; or
 - (ii) One *Manufactured Home*, if on a site greater than 2.0ha.
- (d) Where a Lot rezoned M1-A Abuts Lots zoned for non-industrial Uses, no Use shall direct illumination, light, or glare beyond the boundary of the Lot on which the Use is located.
- (e) No industrial uses are permitted which carry out their operations such that there would be excessive noise, odour, or other emissions created outside an enclosed building. Excessive emissions are those that exceed standards set by Provincial legislation.
- (f) In addition to the regulations listed above, other regulations may apply. These include [Section 4: General Regulations](#); [Section 5: Landscaping and Screening Regulations](#); [Section 6: Parking and Loading Restrictions](#), and [Section 7: Specific Use Regulations](#).

13.0 Public, Openland & Institutional Zones

13.1 PR1 Parks and Recreation Zone

PR1

13.1.1 Purpose

To provide a zone to accommodate open space and outdoor community recreation *Uses*. Lands must be designated as Environmentally Sensitive Areas or Parks under the *District's* Official Community Plan.

13.1.2 Principal Uses

The following *Uses* and no other *Uses* shall be the permitted *Principal Uses* in this zone subject to all applicable regulations of this Bylaw:

- (a) public boat launch;
- (b) public beach;
- (c) cemetery;
- (d) *Marina*, restricted to Lot 1, Plan KAP61478, 17001 Lakeshore Drive;
- (e) playground; and
- (f) *Recreational Services, Outdoor*.

13.1.3 Accessory Uses

The following *Uses* and no other *Uses* shall be the permitted *Accessory Uses* in this zone subject to all applicable regulations of this Bylaw:

- (a) *Accessory Buildings & Structures*;
- (b) *Eating & Drinking Establishment* limited to concession stand facilities; and
- (c) docks.

13.1.4 Development Regulations

- (a) Maximum *Lot Coverage* 25 percent
- (b) Maximum *Floor Area Ratio* 0.5

13.1.5 Siting Regulations – *Principal & Accessory Uses*

- (a) Minimum *Front Setback* 7.0m
- (b) Minimum *Rear Setback* 7.0m
- (c) Minimum *Side Setback (Interior)* 5.0m
- (d) Minimum *Side Setback (Exterior)* 5.0m
- (e) Maximum *Height* The lesser of 9.5m

or 2 Storeys

13.1.6 Other Regulations

- (a) Two concession stands shall be permitted per *Principal Use*, and the maximum *Gross Floor Area* of each concession stand shall be 100m².
- (b) In addition to the regulations listed above, other regulations may apply. These include [Section 4: General Regulations](#), [Section 5: Landscaping and Screening Regulations](#), [Section 6: Parking and Loading Regulations](#), and [Section 7: Specific Use Regulations](#).

13.2 FG Forestry Grazing Zone

FG

13.2.1 Purpose

To provide a zone to accommodate forestry, grazing and conservation *Uses* in areas of the community that are currently confined by the availability of water, roads or other infrastructure and service needs. Lands must be designated as Openland, or Future Growth Areas under the *District's* Official Community Plan.

13.2.2 Principal Uses

The following *Uses* and no other *Uses* shall be the permitted *Principal Uses* in this zone subject to all applicable regulations of this Bylaw:

- (a) forestry;
- (b) *Agriculture, General*, limited to grazing;
- (c) *Manufactured Housing - Type 1 or 2*; and
- (d) *Single Detached Housing*.

13.2.3 Accessory Uses

The following *Uses* and no other *Uses* shall be the permitted *Accessory Uses* in this zone subject to all applicable regulations of this Bylaw:

- (a) *Accessory Buildings & Structures*;
- (b) *Home Occupation - Type 1,2 or 3*; and
- (c) stable.

13.2.4 Subdivision Regulations

- (a) Minimum *Lot Area* 20.0ha

13.2.5 Development Regulations

- (a) Maximum *Lot Coverage* 10 percent

13.2.6 Siting Regulations – *Principal & Accessory Uses*

- (a) Minimum *Front Setback* 10.0m
- (b) Minimum *Rear Setback* 7.0m
- (c) Minimum *Side Setback (Interior)* 7.0m
- (d) Minimum *Side Setback (Exterior)* 7.0m
- (e) Maximum *Height* 12.0m

13.2.7 Other Regulations

- (a) The maximum number of principal *Dwellings* shall not exceed one (1) *Single Detached House* or one (1) *Manufactured House* per Lot or Development Site.
- (b) *Accessory Buildings or Structures* will be limited to a maximum of 100m² or 25% of the allowable Lot Coverage, whichever is greater.
- (c) In addition to the regulations listed above, other regulations may apply. These include [Section 4: General Regulations](#), [Section 5: Landscaping and Screening Regulations](#), [Section 6: Parking and Loading Regulations](#), and [Section 7: Specific Use Regulations](#).

13.3 PP Preservation & Protection Zone

PP

13.3.1 Purpose

To provide a zone to protect land areas in the community that have significant environmental value, are endangered natural habitat or are undevelopable due to topographical or environmental constraints. Lands must be designated as Environmentally Sensitive Development Permit Areas or High Hazard Development Permit Areas under the *District's* Official Community Plan.

13.3.2 Principal Uses

The following *Uses* and no other *Uses* shall be the permitted *Principal Uses* in this zone subject to all applicable regulations of this Bylaw:

- (a) *Agriculture, General*, limited to grazing; and
- (b) *Openland Recreation*.

13.3.3 Other Regulations

- (a) No *Buildings* of any kind other than those required to protect *Government & Utility Services* are permitted within this zone.
- (b) In addition to the regulations listed above, other regulations may apply. These include [Section 4: General Regulations](#), [Section 5: Landscaping and Screening Regulations](#), [Section 6: Parking and Loading Regulations](#), and [Section 7: Specific Use Regulations](#).

13.4 I Institutional Zone

13.4.1 Purpose

To provide a zone to accommodate major community facilities that address institutional, cultural, and educational needs of the community. Lands must be designated as Administration under the *District's* Official Community Plan.

13.4.2 Principal Uses

The following *Uses* and no other *Uses* shall be the permitted *Principal Uses* in this zone subject to all applicable regulations of this Bylaw:

- (a) art gallery and museum;
- (b) *Child Care Centre, Major, Minor;*
- (c) community centre;
- (d) convention centre;
- (e) court house;
- (f) *Funeral Home;*
- (g) *Group Home, Major;*
- (h) hospital;
- (i) library;
- (j) *Place of Worship;*
- (k) *Protective & Emergency Services;*
- (l) *Education Services;*
- (m) *Recreational Services, Indoor;*
- (n) *Recreational Services, Outdoor;*
- (o) *Recycle Drop-Off Centre;* and
- (p) research centre and laboratory.

Bylaw 2017-021 added (b) Dormitory as an accessory use (August 28, 2017)

13.4.3 Accessory Uses

The following *Uses* and no other *Uses* shall be the permitted *Accessory Uses* in this zone subject to all applicable regulations of this Bylaw:

- (a) *Accessory Buildings & Structures;*
- (b) *Dormitory;*
- (c) *Eating & Drinking Establishment;* and

(d) *Employee Housing.*

13.4.4 Subdivision Regulations

(a)	Minimum <i>Lot Area</i>	700m ²
(b)	Minimum <i>Lot Width</i>	18.0m
(c)	Minimum <i>Lot Depth</i>	30.0m

13.4.5 *Development* Regulations

(a)	Maximum <i>Lot Coverage</i>	50 percent
(b)	Maximum <i>Floor Area Ratio</i>	0.8

13.4.6 Siting Regulations – *Principal & Accessory Uses*

(a)	Minimum <i>Front Setback</i>	7.0m
(b)	Minimum <i>Rear Setback</i>	7.0m
(c)	Minimum <i>Side Setback (Interior)</i>	5.0m
(d)	Minimum <i>Side Setback (Exterior)</i>	5.0m
(e)	Maximum <i>Height</i>	The lesser of 14.0m or 4 <i>Storeys</i>

13.4.7 Other Regulations

- (a) *Employee Housing* shall be limited to one (1) *Dwelling* unit per *Lot* or *Development Site*.
- (b) In addition to the regulations listed above, other regulations may apply. These include [Section 4: General Regulations](#), [Section 5: Landscaping and Screening Regulations](#), [Section 6: Parking and Loading Regulations](#), and [Section 7: Specific Use Regulations](#).

14.0 Comprehensive Development Zones

14.1 CD Comprehensive Development Zones

14.1.1 Purpose

To provide a zone which will allow for the creation of customized land use regulations for site-specific *Developments* where the use of other conventional zones in this Bylaw would not accommodate the public interest. Proposed uses and densities must be in conformity with the *District's* Official Community Plan.

14.1.2 Zone Appropriateness

The use of this zoning tool to accommodate any proposed development shall only be considered where the following concerns would apply:

- (a) the use of any other zone in this Bylaw would result in a potential conflict with the scale and character of existing or future surrounding development, should the full development potential of that zone be used; or
- (b) the scale, character or complexity of the contemplated development is so unique that it cannot be appropriately regulated by another zone; or
- (c) the use of any other zone could lead to conflicts with established policies
- (d) and objectives of the District's Official Community Plan.

14.1.3 Applications

Any application to re-zone property to CD - Comprehensive Development Zone shall include the following additional information:

- (a) support rationale explaining why a CD - Comprehensive Development Zone is desirable for the site relative to the zone appropriateness set out in Section 14.1.2 above;
- (b) text of the proposed zone in a format that is similar to the standard zones contained in this Bylaw. This shall include the general purpose of the zone; a list of *Principal* and *secondary Uses* for the zone; a list of subdivision, *Development* and siting regulations for the zone; and a list of other regulations which apply in addition to or instead of any other regulations in this Bylaw;
- (c) site and/or elevation plans to be incorporated as part of the CD-Comprehensive Development Zone where the use of such plans will aid in the clarification and interpretation of the corresponding written regulations; and
- (d) an analysis of the opinions and concerns of the surrounding property owners, if applicable, along with a summary on how the proposed development was modified to respond to those concerns.

14.1.4 Uses

Council, in approving a CD - Comprehensive Development Zone, shall specify the *Uses* permitted under this zoning classification.

14.1.5 Regulations

Council, in approving a CD - Comprehensive Development Zone, shall specify the regulations required under this zoning classification.

14.1.6 Development Permits

Council, in approving a CD - Comprehensive Development Zone, shall specify what parts of a proposed *Development* requires further approval by Council where the use of this zone is or will be within a designated Development Permit Area.

14.1.7 Zoning Map Identification

All approved CD - Comprehensive Development Zones shall be designated on the *District's* zoning map as "CD" followed by a series of sequential reference numbers starting with the number 1.

14.2 CD1 - Comprehensive Development Zone

14.2.1 Purpose

To provide a zone to accommodate specialized housing for senior citizens in the form of *Apartment Housing*. Lands must be designated as HDR - High Density Residential under the *District's* Official Community Plan.

14.2.2 Principal Uses

The following *Uses* and no other *Uses* shall be the *Principal Uses* in this zone subject to all applicable regulations of this Bylaw:

- (a) *Apartment Housing* – senior citizen

14.2.3 Secondary Uses

The following *Uses* and no other *Uses* shall be the secondary *Uses* in this zone subject to all applicable regulations of this Bylaw:

- (a) *Accessory Buildings & Structures*.

14.2.4 Subdivision Regulations

- (a) Minimum *Lot Area* 4,000m²
- (b) Minimum *Lot Width* 30.0m
- (c) Minimum *Lot Depth* 30.0m

14.2.5 Development Regulations

- (a) Minimum *Lot Coverage* 50%
- (b) Maximum *Floor Area Ratio* 1.2
- (c) Maximum *Density* 145 *Dwellings* per ha

14.2.6 Siting Regulations

- (a) Principal *Buildings* and *Structures*:
 - (i) Minimum *Front Setback* 0.0m
 - (ii) Minimum *Rear Setback* 5.0m
 - (iii) Minimum *Side Setback (Interior)* 5.0m
 - (iv) Minimum *Side Setback (Exterior)* 5.0m
 - (v) Maximum *Height* The lesser of 14.0m or 3 *Storeys*

(vi) Notwithstanding Section 14.2.6(a)(v), the proposed parking level shall not be classified as a *Storey* provided that the entire *Building* is sprinklered.

(b) *Accessory Buildings and Structures:*

- | | | |
|-------|--|---------------------------------------|
| (i) | Minimum <i>Front Setback</i> | 0.0m |
| (ii) | Minimum <i>Rear Setback</i> | 1.5m |
| (iii) | Minimum <i>Side Setback (Interior)</i> | 1.5m |
| (iv) | Minimum <i>Side Setback (Exterior)</i> | 5.0m |
| (v) | Maximum <i>Height</i> | The lesser of 4.5m or 1 <i>Storey</i> |

14.2.7 Other Regulations

- (a) In accordance with the *District's* Official Community Plan, all multiple family *Developments* are designated as Development Permit Areas, and for the purpose of this zone, the proposed senior citizen housing complex is considered to be a multiple family *Development*.
- (b) Parking for the housing complex shall be provided at a minimum level of 18 resident parking spaces and 19 visitor/employee parking spaces. All other regulations of Section 6: Parking & Loading Regulations shall remain in effect.
- (c) Outdoor amenity space, in keeping with the *District's* Multiple Family Development Permit guidelines, shall be provided at a rate of 27.5 square meters per *Dwelling*.
- (d) In addition to the regulations listed above, other regulations may apply. These include [Section 4: General Regulations](#), [Section 5: Landscaping and Screening Regulations](#), [Section 6: Parking and Loading Regulations](#), and [Section 7: Specific Use Regulations](#).

14.3 CD2 – Comprehensive Development Zone

14.3.1 Purpose

To provide a zone to accommodate a resort *Development* adjacent to Okanagan Lake in the Lower Town Development Permit Area as defined in Schedule “F” of the *District’s* Official Community Plan. Lands must be designated TC-Tourist Commercial under the *District’s* Official Community Plan.

14.3.2 Principal Uses

The following *Uses* and no other *Uses* shall be the *Principal Uses* in this zone subject to all applicable regulations of this Bylaw:

- (a) resorts, defined as a hotel with individual cooking facilities being permitted in each guestroom.

14.3.3 Secondary Uses

The following *Uses* and no other *Uses* shall be the secondary *Uses* in the zone subject to all applicable regulations of this Bylaw:

- (a) *Accessory Buildings and Structures.*

14.3.4 Development Regulations

- (a) Maximum Lot Coverage 50%
- (b) Maximum Gross Floor Area 5,250m²

14.3.5 Siting Regulations – *Principal & Secondary Uses*

- (a) Maximum *Front Setback* 0.9m for up to 40% of the *Lot* width with the balance having a minimum *Setback* requirement of 2.5m
- (b) Minimum *Rear Setback* 6.0m from the natural boundary plotted from the survey plan DL 5204 as shown on Lot A, DL 455 and DL 5204, Plan 33645, ODYD
- (c) Minimum *Side Yard Setback (Interior, North)* 2.1m
- (d) Minimum *Side Yard Setback (Interior, South)* 0.0

- (e) *Maximum Height* The lesser of 14.5m or 3 *Storeys*
- (f) Notwithstanding Section 14.3.5(c) and Section 14.3.5(d) of this Bylaw, roof overhangs may project 1.2m into the required *Side Interior Setback*.
- (g) Notwithstanding Section 14.3.5(c)(d) of this Bylaw, the underground parking garage may extend to within 1.2m of the property line provided the top of the structure is not more than 2.0m above natural grade.
- (h) Notwithstanding Section 14.3.5(e) and Section 14.3.5(g) of this Bylaw, the proposed parking level and mezzanines shall be classified as a *Storey*.

14.3.6 Other Regulations

- (a) Parking for the resort complex shall be provided in conformance with the parking requirements for *Hotels* identified under Section 6: Parking and Loading Regulations of this Bylaw.
- (b) The siting, size and dimensions of *Buildings* and *Structures* shall be in compliance with the plans attached to this Bylaw and dated June 1, 2000.
- (c) A resort use in this zone is not required to comply with the road dedication requirements of Section 4.7 Setbacks from Highways and Major Streets of this Bylaw.
- (d) In addition to the regulations listed above, other regulations may apply. These include [Section 4: General Regulations](#), [Section 5: Landscaping and Screening Regulations](#), [Section 6: Parking and Loading Regulations](#), and [Section 7: Specific Use Regulations](#).

14.4 CD3 – Comprehensive Development Zone

14.4.1 Purpose

To provide a zone to accommodate the comprehensive *Development of Single Detached Housing* on smaller *Lots* having *Full Urban Services* in a bare land strata format. Lands must be designated as MDR – Medium Density Residential under the *District’s Official Community Plan*.

14.4.2 Principal Uses

The following *Uses* and no other *Uses* shall be the *Principal Uses* in this zone subject to all applicable regulations of this Bylaw:

- (a) *Single Detached Housing*

14.4.3 Secondary Uses

The following *Uses* and no other *Uses* shall be the secondary *Uses* in this zone subject to all applicable regulations of this Bylaw:

- (a) *Accessory Buildings and Structures*.
- (b) *Home Occupations – Type 1*.

14.4.4 Subdivision Regulations

- (a) *Minimum Development Site Area* 4,000m²
- (b) *Minimum Development Site Width* 40.0m
- (c) *Minimum Development Site Depth* 200m
- (d) *Minimum Lot Area* 235m²
- (e) *Minimum Lot Width* 7.5m

14.4.5 Development Regulations

- (a) *Maximum Lot Coverage* 40%
- (b) *Maximum Floor Area Ratio* 0.55
- (c) *Maximum Density* 20 *Dwellings* per ha

14.4.6 Siting Regulations

- (a) *Principal Buildings and Structures*:
 - (i) *Minimum Front Setback* 4.5m
 - (ii) *Minimum Rear Setback* 4.0m
 - (iii) *Minimum Side Setback* 1.5m

- (iv) *(Interior)* Minimum *Side Setback* 4.6m
(Exterior)
 - (v) Maximum *Height* The lesser of 9.0m or 2 *Storeys*
 - (vi) Notwithstanding Section 14.4.6(a)(iii), a *Lot* having no direct vehicular access to the rear yard without a garage or carport shall maintain one *Side Yard Setback* of at least 3.0 meters.
- (b) Principal *Buildings* and *Structures*:
- (i) Minimum *Front Setback* 4.5m
 - (ii) Minimum *Rear Setback* 1.5m
 - (iii) Minimum *Side Setback* 1.5m
(Interior)
 - (iv) Minimum *Side Setback* 4.0m
(Exterior)
 - (v) Maximum *Height* The lesser of 4.5m or 1 *Storey*

14.4.7 Other Regulations

- (a) Only one (1) *Dwelling* will be permitted per *Lot* site.
- (b) All roads and services within the *Development Site* shall meet the regulations of the *District's* Subdivision and Development Servicing Bylaw.
- (c) Only one (1) *Accessory Building* or *Structure* will be allowed per *Lot* with a maximum *Gross Floor Area* of 10.0m².
- (d) No communal parking, loading, garbage collection facilities or individual driveways other than the existing *Dwelling* at 10602 Victoria Road South shall be permitted have direct access to the *Abutting* public *Highway*.
- (e) In addition to the regulations listed above, other regulations may apply. These include [Section 4: General Regulations](#), [Section 5: Landscaping and Screening Regulations](#), [Section 6: Parking and Loading Regulations](#), and [Section 7: Specific Use Regulations](#).

14.5 CD4 - Comprehensive Development Zone

14.5.1 Purpose

To provide a zone to accommodate a seniors' care complex providing a combination of residential care beds (*Group Home, Major*) and assisted living units. Lands must be designated as A - Administration under the *District's* Official Community Plan.

14.5.2 Principal Uses

The following *Uses* and no other *Uses* shall be the *Principal Uses* in this zone subject to all applicable regulations of this Bylaw:

- (a) Assisted living units*
- (b) *Group Home, Major.*

*For the purpose of this zone, assisted living units are defined as *Apartment Housing* intended for senior citizens who by reason of physical or mental difficulties require some professional assistance to meet their day-to-day living activities.

14.5.3 Secondary Uses

The following *Uses* and no other *Uses* shall be the secondary *Uses* in this zone subject to all applicable regulations of this Bylaw:

- (a) *Accessory Buildings & Structures.*
- (b) *Eating and Drinking Establishments* for the residents.
- (c) *Recreational Services, Indoor* for the residents.

14.5.4 Subdivision Regulations

- (a) Minimum *Lot Area* 1.6ha
- (b) Minimum *Lot Width* 125m
- (c) Minimum *Lot Depth* 125m

14.5.5 Development Regulations

- (a) Maximum *Lot Coverage* 40%
- (b) Maximum *Floor Area Ratio* 1.15
- (c) Maximum *Density* 90 *Dwellings* per ha

14.5.6 Siting Regulations

- (a) Principal *Buildings and Structures:*

- (i) Minimum *Front Setback* 6.0m
- (ii) Minimum *Rear Setback* 8.0m
- (iii) Minimum *Side Setback (Interior)* 5.0m
- (iv) Minimum *Side Setback (Exterior)* 0.9m
- (v) Maximum *Height* The lesser of 18.0m or 4 *Storeys*
- (vi) Notwithstanding Section 14.5.6(a)(v), the proposed parking level shall not be classified as a *Storey*.

(b) Principal *Buildings and Structures*:

- (i) Minimum *Front Setback* 6.0m
- (ii) Minimum *Rear Setback* 8.0m
- (iii) Minimum *Side Setback (Interior)* 5.0m
- (iv) Minimum *Side Setback (Exterior)* 0.9m
- (v) Maximum *Height* The lesser of 4.5m or 1 *Storey*

14.5.7 Other Regulations

- (a) In accordance with the *District's* Official Community Plan, all multiple family *Developments* are designated as Development Permit Areas, and for the purpose of this zone, the proposed assisted living units are not considered to be a multiple family *Development*.
- (b) Parking for the housing complex shall be based on one parking stall per 4 bedrooms for *Group Homes, Major* plus one parking stall per 3 *Dwelling* units for the assisted living units. All other regulations of Section 6: Parking & Loading Regulations shall remain in effect.
- (c) The seniors care complex is required to comply with the road dedication requirements of Section 4.7 Setbacks from Highways and Major Streets of this Bylaw.
- (d) In addition to the regulations listed above, other regulations may apply. These include [Section 4: General Regulations](#), [Section 5: Landscaping and Screening Regulations](#), [Section 6: Parking and Loading Regulations](#), and [Section 7: Specific Use Regulations](#).

14.6 CD5 – Comprehensive Development Zone

14.6.1 Purpose

To provide a zone to accommodate a resort *Development* adjacent to Okanagan Lake in the Lower Town Development Permit Area as defined in Schedule “F” of the *District’s* Official Community Plan. Lands must be designated TC-Tourist Commercial under the *District’s* Official Community Plan.

14.6.2 Principal Uses

The following *Uses* and no other *Uses* shall be the *Principal Uses* in this zone subject to all applicable regulations of this Bylaw:

- (a) resorts, defined as a *Hotel* with individual cooking facilities being permitted in each guestroom.

14.6.3 Secondary Uses

The following *Uses* and no other *Uses* shall be the secondary *Uses* in the zone subject to all applicable regulations of this Bylaw:

- (a) *Accessory Buildings and Structures*.

14.6.4 Development Regulations

- (a) Maximum *Lot Coverage* 50%
- (b) Maximum *Floor Area Ratio* 1.0

14.6.5 Siting Regulations – *Principal & Secondary Uses*

- (a) Maximum *Front Setback* 0.9m for up to 40% of the *Lot* width with the balance having a minimum *Setback* requirement of 2.5m
- (b) Minimum *Rear Setback* 3.5m
- (c) Minimum *Side Setback (Interior)* 3.0m
- (d) Minimum *Side Setback (Exterior)* 3.0m
- (e) Maximum *Height* The lesser of 16.2m or 3 *Storeys*
- (f) Notwithstanding Section 14.6.5(b), the hot tub terrace and deck may extend up to the *Rear Property Line*.
- (g) Notwithstanding Section 14.6.5(c), the line-of-entry canopy located on the south elevation of the resort can extend up to .30 meters of the south *Property Line*.

- (h) Notwithstanding Section 14.6.5(e), the proposed parking level and mezzanines shall be classified as a *Storey*

14.6.6 Other Regulations

- (a) The general design and proposed layout of the resort *Development* shall be in keeping with the plans attached to this *Bylaw* and dated December 20, 2002.
- (b) The resort use in this zone is not required to comply with the road dedication requirements of Section 4.7 Setbacks from Highways and Major Streets of this Bylaw.
- (c) In addition to the regulations listed above, other regulations may apply. These include [Section 4: General Regulations](#), [Section 5: Landscaping and Screening Regulations](#), [Section 6: Parking and Loading Regulations](#), and [Section 7: Specific Use Regulations](#).

14.7 CD6 – Comprehensive Development Zone

FINAL READING AND ADOPTION OF THE CD6 ZONE HAS NOT YET TAKEN PLACE

14.8 CD7 – Comprehensive Development Zone

Bylaw 2012-010 revised the regulations in the CD7 Zone, as follows: (May 14th, 2012)

14.8.1 Purpose

To provide a zone to accommodate a mixed-use infill *Development* adjacent to the downtown core having a unique architectural style. Lands must be designated DC – Downtown Commercial under the District’s Official Community Plan.

14.8.2 Principal Uses

The following *Uses* and no other *Uses* shall be the *Principal Uses* in this zone subject to all applicable regulations of this Bylaw:

- (a) Art galleries & museums;
- (b) *Community Recreational Services*;
- (c) *Dwelling* units above the main floor;
- (d) Group Home Major;
- (e) *Eating & Drinking Establishments*;
- (f) Health Services;
- (g) *Financial Services*;
- (h) Personal Services Establishments;
- (i) libraries;
- (j) *Offices*;
- (k) *Retail Stores, General*;
- (l) Private Clubs;
- (m) Wine & Beer stores.

14.8.3 Accessory *Uses*

The following *Uses* and no other *Uses* shall be the secondary *Uses* in the zone subject to all applicable regulations of this Bylaw:

- (a) Home Occupations – Type 1;
- (b) Accessory Buildings and Structures;

- (c) Public Open Space, Town Square.

14.8.4 Development Regulations

- (a) Maximum *Lot Coverage*:
 - (i) Buildings A1, A2, A3 & B (main floor) 60%
- (b) Development in accordance with the attached Summerland Plaza Conceptual Plan, dated March 30th, 2012
- (c) Floor Area Ratio (FAR) – 2.5 (max.)

14.8.5 Siting Regulation – *Principal Uses*

The required setbacks for the proposed stepped *Building* design shall be in keeping with site layout plan dated March 20th, 2012 prepared by The District of Summerland.

- (a) Maximum *Height* 25.0 metres
- (b) Minimum *Height* 11.0 metres
- (c) Setback from front & side exterior 2.4 metres
- (d) Setback from side & rear interior 0.0 metres

14.8.6 Other Regulations

- (a) The general design and proposed layout of the *Development* shall be in keeping with the plans attached to this Bylaw dated March 20, 2012 and referred to as CD7-A, Plan 1 to 5 inclusive.
- (b) Parking for the *Development* shall be provided based on the following calculations:
 - (i) 1 parking stall per residential *Dwelling* unit plus
 - (ii) 1 parking stall per 95m² of *Gross Floor Area* for all commercial/institutional uses plus
- (c) In addition to the regulations listed above, other regulations may apply. These include [Section 4: General Regulations](#), [Section 5: Landscaping and Screening Regulations](#), [Section 6: Parking and Loading Regulations](#), and [Section 7: Specific Use Regulations](#).
- (d) Fee in lieu of parking in accordance with CB-1, 6.4.1;



SUMMERLAND PLAZA

PRELIMINARY CONCEPT PLAN



SUMMERLAND PLAZA

PRELIMINARY CONCEPT PLAN - SECOND FLOOR

Plan 2

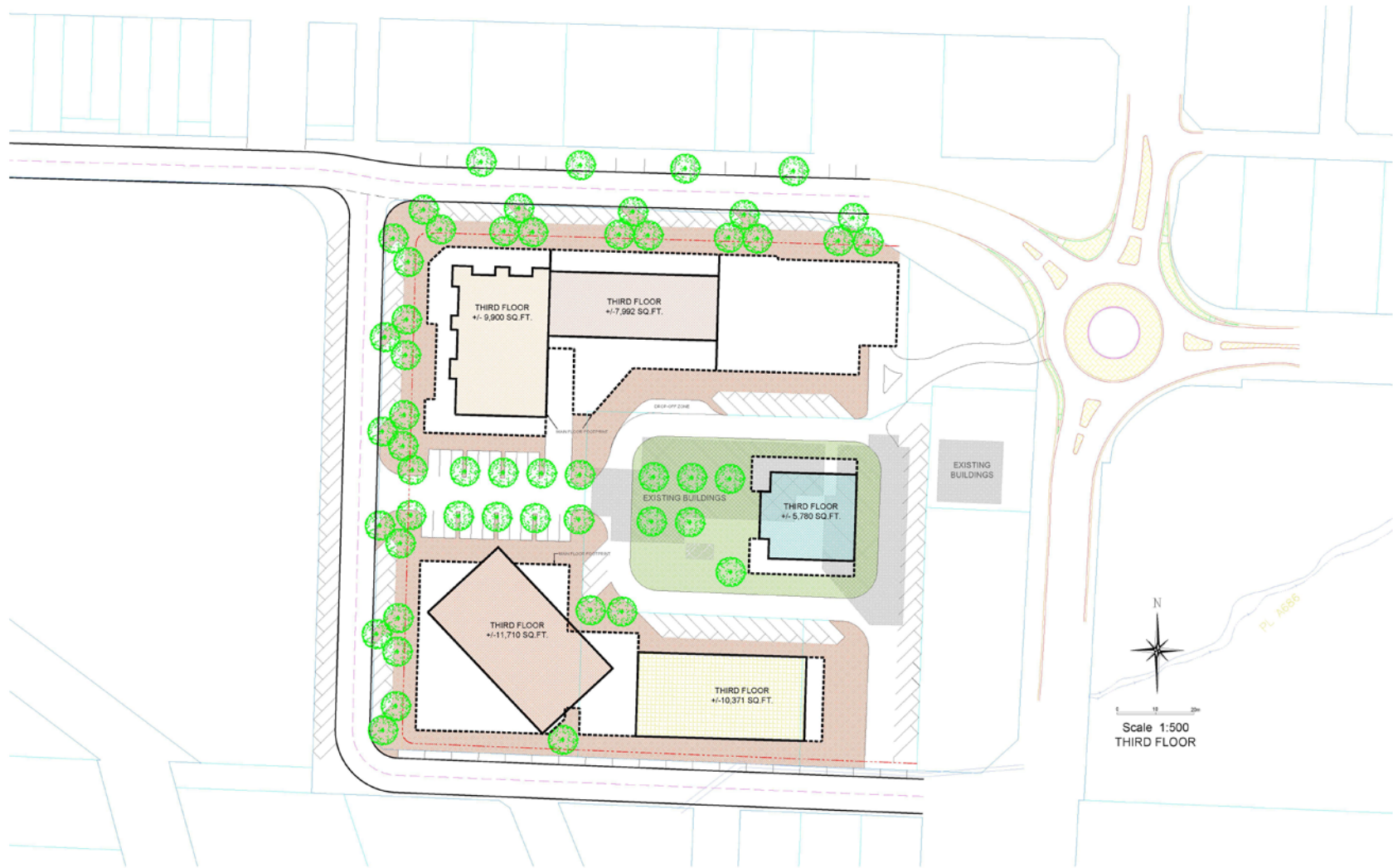

SUMMERLAND PLAZA

PRELIMINARY CONCEPT PLAN - THIRD FLOOR

Plan 4

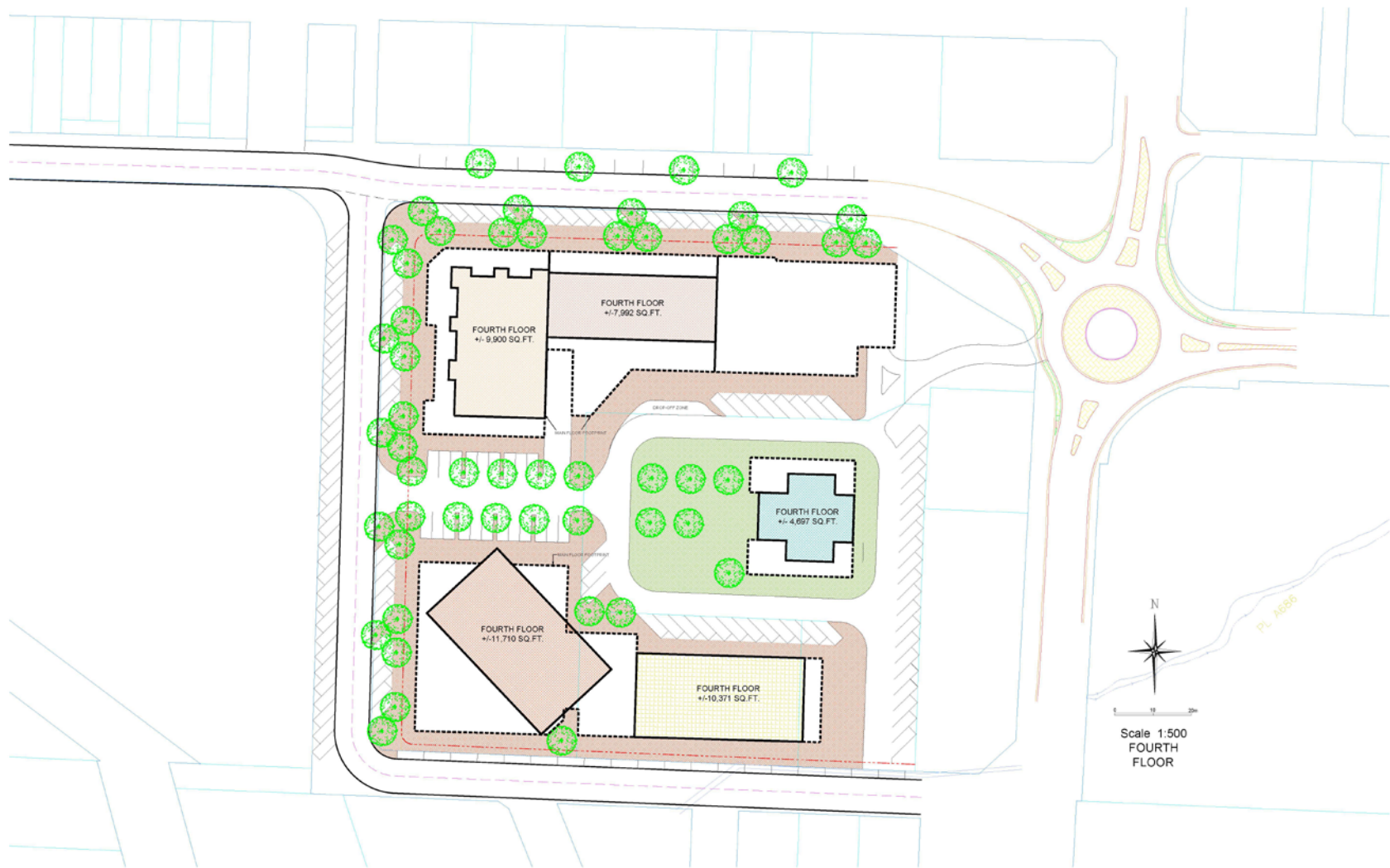

SUMMERLAND PLAZA

PRELIMINARY CONCEPT PLAN - FOURTH FLOOR

Plan 5

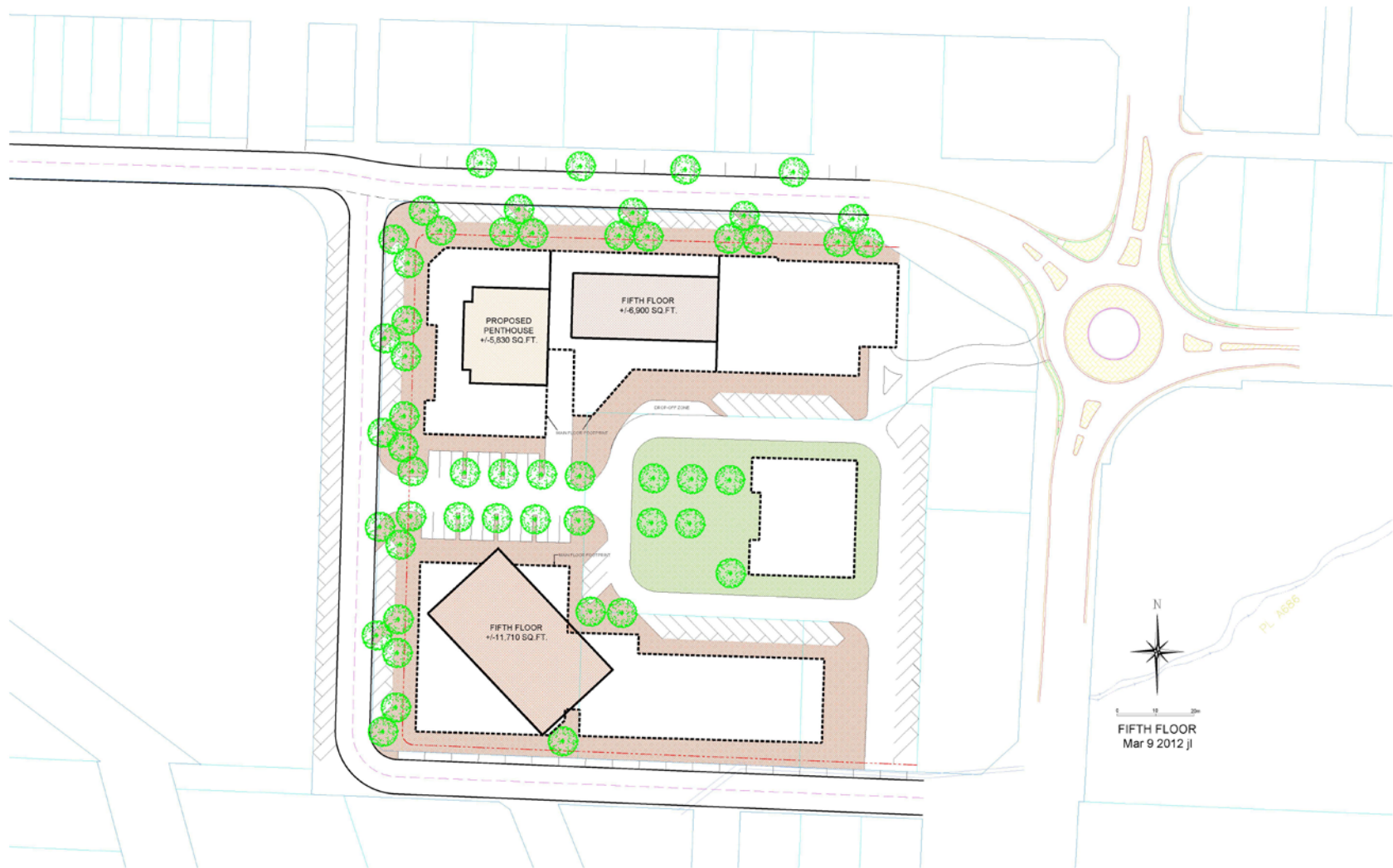

SUMMERLAND PLAZA
PRELIMINARY CONCEPT PLAN - FIFTH FLOOR

14.9

14.10 CD9 – Comprehensive Development Zone

14.10.1 Purpose

To provide a site-specific zone to accommodate the comprehensive *Development of Single Detached Housing with Secondary Suites* on compact urban *Lots* having *Full Urban Services*.

14.10.2 Principal Uses

The following *Uses* and no other *Uses* shall be the permitted *Principal Uses* in this zone subject to all applicable regulations of this Bylaw:

- (a) *Single Detached Housing*.

14.10.3 Accessory Uses

The following *Uses* and no other *Uses* shall be the permitted *Accessory Uses* in this zone subject to all applicable regulations of this Bylaw:

- (a) *Accessory Buildings and Structures*;
- (b) *Child Care Centre, Minor*;
- (c) *Carriage House*;
- (d) *Group Home, Minor*;
- (e) *Home Occupation - Type 1 or 2*; and
- (f) *Secondary Suite*.

14.10.4 Subdivision Regulations

- (a) *Minimum Lot Area* 250m²
- (b) *Minimum Lot Width* 7.5m
- (c) *Minimum Lot Depth* 30.0m

14.10.5 Development Regulations

- (a) *Maximum Lot Coverage* 40 percent
- (b) *Maximum Floor Area Ratio* 0.5

14.10.6 Siting Regulations

- (a) *Principal Buildings and Structures*:
 - (i) *Minimum Front Setback* 6.0m
 - (ii) *Minimum Rear Setback* 6.0m

- (iii) Minimum *Side Setback (Interior)* 1.2m
- (iv) Minimum *Side Setback (Exterior)* 4.5m
- (v) Maximum *Height* The lesser of 9.5m or 2 *Storeys*

(b) *Accessory Buildings and Structures*

- (i) Minimum *Front Setback* 6.0m
- (ii) Minimum *Rear Setback* 1.5m
- (iii) Minimum *Side Setback (Interior)* 1.2m
- (iv) Minimum *Side Setback (Exterior)* 4.5m
- (v) Maximum *Height* The lesser of 4.5m or 1 *Storey (see vi)*
- (vi) Notwithstanding Section 10.1.6(b)(v), the maximum *Height* for an *Accessory Building* where a *Carriage House* is located over a garage is the lesser of 7.5m or 2 *Storeys*.

14.10.7 Other Regulations

- (a) Only one (1) principal *Dwelling* will be permitted per *Lot*.
- (b) *Accessory Buildings* or *Structures* will be limited to a maximum of 75m² or 25% of the allowable *Lot* coverage, whichever is greater.
- (c) A minimum of one vehicle parking stall per *Single Detached House* and *Secondary Suite* is required. Where a lane is available, all vehicle parking shall be accessed from the lane.
- (d) In addition to the regulations listed above, other regulations may apply. These include [Section 4: General Regulations](#), [Section 5: Landscaping and Screening Regulations](#), [Section 6: Parking and Loading Regulations](#), and [Section 7: Specific Use Regulations](#)

Bylaw 2016-028 amendment added Section 15.0 Water Zones - (October 24, 2016)

15.0 WATER ZONES

15.1 WZ1 – Recreational Water Use Zone 1

15.1.1 Purpose

To provide a zone that allows for the recreational enjoyment of upland property owners and foreshore public access while minimizing impacts on fish, wildlife, and vegetation communities.

15.1.2 Principal Uses

The following Uses and no other Uses shall be permitted Principal Uses in this zone subject to all applicable regulations of this Bylaw:

- a) boating;
- b) foreshore public access (including public boat launches adjacent to public roads);
- c) recreational water activities;
- d) uses permitted by Provincial Crown Lands; and
- e) public utilities (municipal, provincial or federal).

15.1.3 Accessory Uses (if a principal use is occurring on the upland lot)

- a) docks;
- b) boat lifts if part of a dock; and
- c) temporary moorage.

15.1.4 Subdivision Regulations

N/A

15.1.5 Development Regulations

N/A

15.1.6 Other Regulations

- a) In addition to the regulations listed above, other regulations may apply. These include Section 7.5 Dock & Boat Lift Regulations.
- b) Boating activity is restricted to those areas not marked as swimming areas by the placement of buoys approved by local, provincial or federal governments.

15.2 WZ2 – Recreational Water Use Zone 2

15.2.1 Purpose

To provide a zone that allows for the recreational enjoyment of the lake but prohibits moorage or docks beyond 100 m.

15.2.2 Principal Uses

The following Uses and no other Uses shall be permitted Principal Uses in this zone subject to all applicable regulations of this Bylaw:

- a) boating;
- b) recreational water activities;
- c) uses permitted by Provincial Crown Lands; and
- d) public utilities (municipal, provincial or federal).

15.2.3 Accessory Uses (if a principal use is occurring on the upland lot)

N/A

15.2.4 Subdivision Regulations

N/A

15.2.5 Development Regulations

N/A

15.2.6 Other Regulations

- a) Boating activity is restricted to those areas not marked as swimming areas by the placement of buoys approved by local, provincial or federal governments.

15.3 WZ3 – Intensive Water Use Zone

15.3.1 Purpose

To provide for a diverse and concentrated range of water activities of a public or commercial nature, consistent with the upland use, maintaining foreshore public access, and minimizing impacts on fish, wildlife, and vegetation communities.

15.3.2 Principal Uses

- a) boat launches
- b) boat lifts
- c) boating
- d) docks
- e) fish hatcheries
- f) foreshore public access
- g) marinas
- h) marina equipment rentals
- i) public utilities (municipal, provincial or federal)
- j) recreational water activities
- k) temporary moorage
- l) uses permitted by Provincial Crown Lands
- m) water feature installations

15.3.3 Accessory Uses

- a) marine fuel facilities
- b) marine sani-dump facilities

15.3.4 Subdivision Regulations

N/A

15.3.5 Development Regulations

N/A

15.3.6 Other Regulations

- a) In addition to the regulations listed above, other regulations may apply. These include Section 7.5 Dock & Boat Lift Regulations
- b) Boating activity is restricted to those areas not marked as swimming areas by the placement of buoys approved by local, provincial or federal governments.

16.0 SUMMARY OF ZONING BYLAW AMENDMENTS

BYLAW NO.	DESCRIPTION	DATE ADOPTED
2000-459	Text Amendment to create an animal shelter, minor use and allow the use in the CB1 and CB2 zones (Section 2.0 Definitions; Sections 8.1; 8.2; 11.5; 11.6 and 12.2)	Nov 14, 2011
2000-462	Zoning amendment – 5806 Lewes Avenue	June 25, 2012
2000-464	Text Amendment to increase the permitted height of residential accessory buildings in the agricultural zones (Sections 8.1.5 and 8.2.5 Ag Zones)	Dec 12, 2011
2000-465	Text Amendment to remove the requirement for an agricultural buffer where properties do not abut ALR lands (Section 5.0 Landscaping Regulations)	Dec 12, 2011
2012-001	Text Amendment to remove a principal use – Subsection 11.1.2 CN – Neighbourhood Commercial Zone	Jan 23, 2012
2012-010	Text Amendment to CD7 Zone	May 14, 2012
2012-017	Housekeeping Text Amendments	July 23, 2012
2012-018	Zoning Amendment (map) – 16207 Hwy 97 and 15600 Hwy 97	July 23, 2012
2012-021	Zoning Amendment – 8218 Pollock	April 8, 2013
2012-022	Zoning Amendment and OCP – mapping – 14806 Biagioni	Nov 26, 2012
2012-025	Zoning Amendment (text) housekeeping – Ag setbacks	Nov 26, 2012
2012-027	Zoning Amendment (text) – site specific 18217 and 18219 Bentley Road	Jan 14, 2013
2012-028	Zoning Amendment – Residential Accessory Buildings	Jan 14, 2013
2013-003	Zoning Amendment – Bentley Road Industrial Area	Mar 11, 2013
2013-008	Zoning Amendment – Prohibit Abattoirs in the Industrial Zones	Apr 29, 2013
2013-012	Zoning Amendment & Map – 10918 Rennie St (M1-A Zone)	Aug 26, 2013
2013-015	Zoning Amendment – Add the CB1-Central Business Zone	June 24, 2013
2013-025	Zoning Amendment – 9348 Alder Street	Dec 9, 2013
2014-006	Zoning Amendment – to add RPN Zone and amend Table 6.1 – Parking & Loading (Housing) and; Zoning Classification for 8709 Jubilee Road from I-Institutional Zone to RPN-Residential Pocket Neighbourhood Zone	June 23, 2014
2014-007	Zoning Amendment – Bentley Rd	June 23, 2014
2014-010	Site Specific Zoning Amendment – 11208 Sanborn	July 28, 2014
2014-015	Rezone – 6003 Dale Avenue	Sept 8, 2014
2014-017	Zoning – Definition Amendment – Front Property Line	Aug 25, 2014

2014-018	Zoning Amendment – 12262 Saunders Cres	Sept 8, 2014
2014-029	Zoning Amendment to create a new Temporary Use Permit Area for (8911 and 9310 Jubilee Road)	Nov 10, 2014
2014-033	Zoning Amendment – 10120 Rand Street	Jan 26, 2015
2015-003	Zoning Amendment – 5815 Hwy 97	May 25, 2015
2015-008	Zoning Amendment – 2705 Johnson Street	May 11, 2015
2015-009	Zoning Amendment – Minor Text Amendments	May 11, 2015
2015-010	Zoning Amendment – 4816 Nixon Rd	May 11, 2015
2015-026	Zoning Amendment – 35888 Garnet Valley Road	Oct 13, 2015
2015-024	Text Amendment – Breweries, Distilleries and Meaderies in the A1 and A2 Zones	Nov 9, 2015
2015-027	Text Amendment – Cluster Development on Two Properties in the CR1-Country Residential Zone (Hunter’s Hill)	Nov 23, 2015
2015-030	Zoning Amendment – 5818 Nixon Road (from RSD2 to RSD1)	Nov 23, 2015
2015-031	Text Amendment – Creates a new Temporary Use Permit Area (13415 Lakeshore Drive)	Nov 9, 2015
2016-005	Text Amendment – Increase maximum gross floor area of a Carriage House for lots over 1,000m ²	April 11, 2016
2016-007	Zoning Amendment – Schedule B - 1109 Stonor Street	April 11, 2016
2016-018	Text Amendment – Delete Section 10.6.5(c) and renumber the sections accordingly	May 24, 2016
2016-020	Zoning Amendment – Schedule B – Parks in Lower Town	July 12, 2016
2016-022	Zoning Amendment – Schedule B – 2311 Thornber Street	July 12, 2016
2016-027	Zoning Amendment – Schedule B – Parks in Lower Town 2	August 22, 2016
2016-031	Zoning Amendment – Schedule A – Child Care Centre, Minor	Sept 12, 2016
2016-032	Zoning Amendment – Schedule B – 12223 Saunders Crescent	Sept 12, 2016
2016-034	Zoning Amendment – Schedule B – 9600 Victoria Road	Sept 12, 2016
2016-028	Zoning Amendment – Addition of Water Zones	Oct 24, 2016
2016-041	Zoning Amendment – Schedule B – Conkle Mountain Park	Nov 28, 2016
2016-045	Zoning Amendment – Schedule B – 11714 Quinpool Road	Dec 12, 2016
2017-003	Zoning Amendment – Schedule B – 2810 Landry Crescent	March 13, 2017
2017-005	Zoning Amendment – Schedule B – 14600 Cartwright Ave	June 12, 2017
2017-017	Zoning Amendment – Schedule B – 11907 Quinpool Rd	June 26, 2017
2017-020	Zoning Amendment – Schedule B – 5010 Croil Ave	July 24, 2017
2017-021	Zoning Amendment – Schedule A - Text Amendment (Dormitory)	Aug 28, 2017
2017-028	Zoning Amendment – Schedule A – Text Amendment (Building Envelope)	Oct 10, 2017
2017-031	Zoning Amendment – Schedule B – 10701 & 10705 Elliott St	Nov 14, 2017
2017-032	Zoning Amendment – Schedule A – Text Amendment (Secondary Suites and Carriage Houses)	Nov 27, 2017

